



ULTRACARE

At the Cutting Edge of Industry

XE220

**THROUGH FEED FOUR
SIDE PLANING
MACHINE**

ILLUSTRATED PARTS BOOK No.2036

**ILLUSTRATED PARTS LIST**

- 1 Bedplate Charts
- 2 First Bottom Head
- 3 Fence Side Head Carriage Adjusting Mechanism
- 4 Top Head Power Rise and Fall
- 5 Outboard Bearing Second Bottom Head
- 6 Top Head Pressure Pad
- 7 Side Pressure before Near Side Head and Guard over First Bottom Head
- 8 Top Head Chipbreaker
- 9 Outboard Bearing First Bottom Head
- 10 Outboard Bearing Top Heads
- 11 Variable Speed Drive
- 12 Fence Side Head Spindle Unit (40mm dia)
- 13 Fence Side Head Spindle Unit (45mm, 50mm and 0.8in dia)
- 14 Near Side Head Spindle Unit (40mm dia)
- 15 Near Side Head Spindle Unit (45mm, 50mm and 0.8in dia)
- 16 Top Head Spindle Unit (4mm dia)
- 17 Top Head Spindle Unit (45mm, 50mm and 0.8in dia)
- 18 Bottom Head Spindle Unit (40mm dia)
- 19 Bottom Head Spindle Unit (45mm, 50mm and 0.8in dia)
- 20 Near Side Head Carriage Unit Adjusting Mechanism
- 21 Top Roller Pressure Unit
- 22 Single Side Roller Pressure Unit Opposite Fence Side Head
- 23 Mounting for Top Pad or Roller Pressure Unit before Top Head
- 24 Universal Head Adjusting Mechanism
- 25 Near Side Head Jointer
- 26 Fence Side Head Jointer
- 27 Top Head Jointer
- 28 Second Bottom Head Jointer
- 29 Bottom Head Rise and Fall
- 30 Bottom Heads Axial Adjustment
- 31 Top Heads Axial Adjustment
- 32 Double Through Feed Gearbox
- 33 Single Through Feed Gearbox
- 34 Single Through Feed Gearbox used with Bottom Roll Drive
- 35 Bottom Feed Roll Drive Transfer
- 36 Shaft Drives
- 37 Near Side Head Chipbreaker
- 38 Second Bottom Head Axial Adjustment
- 39 Throating Head
- 40 Throating Head Spindle Assembly
- 41 Hydraulic Drive Unit
- 42 Bottom Head Pad Pressure
- 43 Pneumatic Pad Pressure
- 44 Segmented Chipbreaker
- 45 Push Feed System

Note:

When ordering spares, please quote machine model and number.



1. BEDPLATES FOR STANDARD FIVE AND SIX HEAD MACHINES

| Ref. No. | Description | No. Off |
|----------|--|---------|
| 1 | Nose for bedplate | 2 |
| 2 | Retaining plate before first fence side head | 1 |
| 3 | Bedplate before fence side head | 1 |
| 4 | Bedplate for fence and near side heads | 2 |
| 5 | Retaining plate between side heads | 1 |
| 6 | Retaining plate after side heads | 1 |
| 7 | Bedplate after near side head | 1 |
| 8 | Bedplate insert after second top head | 1 |
| 9 | Bedplate before second bottom head | 1 |
| 10 | Bedplate after second bottom head | 1 |
| 11 | Bedplate after bedroll | 1 |
| 12 | Bedplate under top head | 1 |
| 13 | Bedplate before second bottom head | 1 |
| 14 | Bedplate after second bottom | 1 |
| 15 | Bedplate after bedroll | 1 |
| 16 | Bedplate between side heads | 1 |

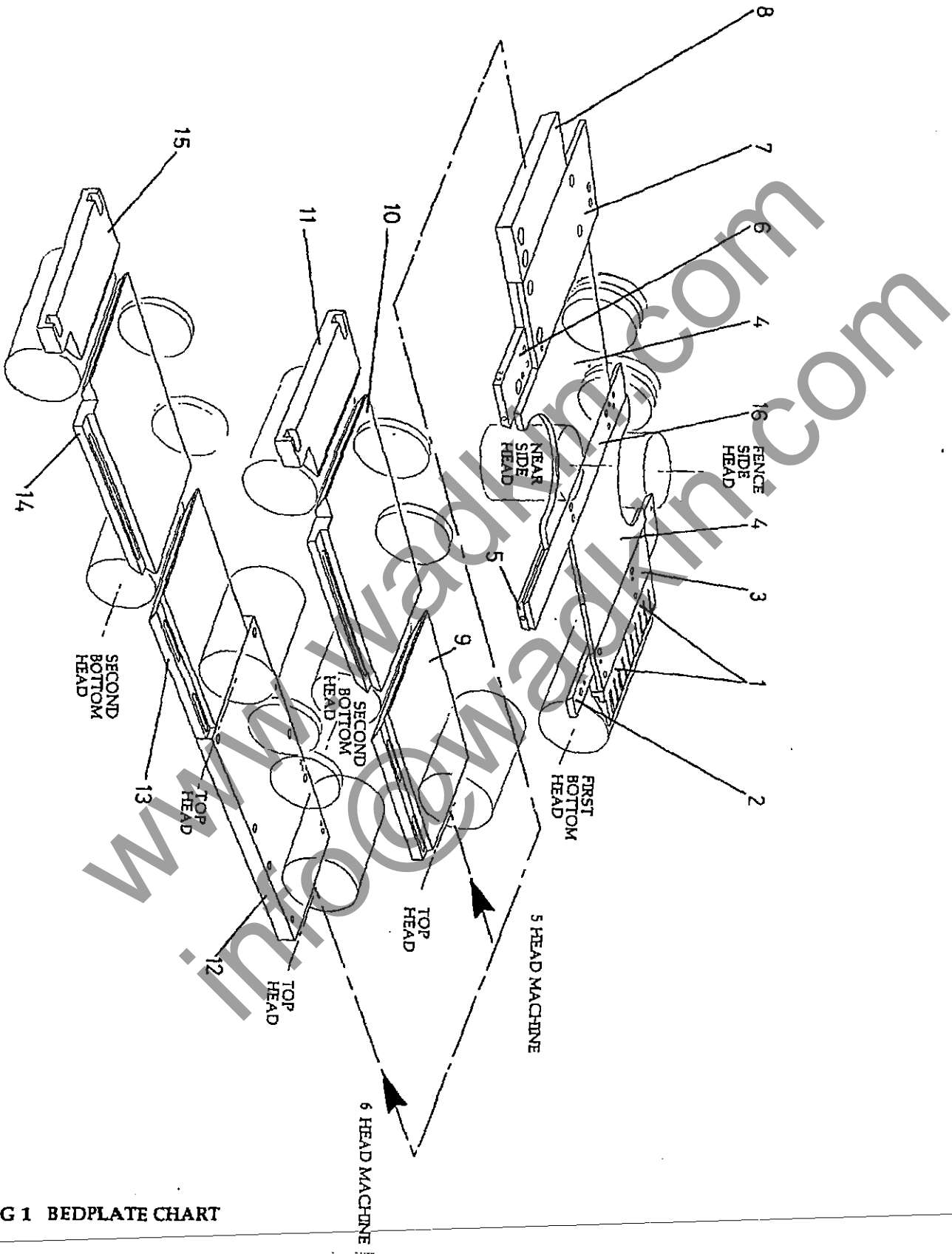

FIG 1 BEDPLATE CHART



2. FIRST BOTTOM HEAD

| Ref. No. | Description | No. Off |
|----------|--|---------|
| 1 | Outboard bearing (see separate illustration) | 1 |
| 2 | Cutterblock | 1 |
| 3 | Spindle (see separate illustrations) | 1 |
| 4 | Housing for outboard bearing | 1 |
| 5 | Slide strip | 1 |
| 6 | Bottom Head spindle housing, vertical slide | 1 |
| 7 | Pulley belt housing, horizontal heads | 1 |
| 8 | Spindle pulley, bottom and Top Heads | 1 |
| 9 | Fenner vee belt, SPZ 850 | 2 or 3 |
| 10 | Fenner vee belt pulley} see Tables | 1 |
| 11 | Fenner Taper-Lock bush} | 1 |
| 12 | Hexagon head screw, M10 x 30mm long | 4 |
| 13 | Spring washer, 10mm diameter, single coil | 4 |
| 14 | Bracket nut, Bottom Head vertical adjustment | 1 |
| 15 | Vertical adjustment screw, First Bottom Head | 1 |
| 16 | Hexagon socket capscrews, M6 x 75mm long | 4 |
| 17 | Bevel box, Bottom Head vertical adjustment | 1 |
| 18 | Bevel gear wheel | 1 |
| 19 | Bearing washer, top and bottom | 2 |
| 20 | Thrust washer | 1 |
| 21 | M16 hexagonal nut | 2 |
| 22 | Parallel key 5mm x 5mm x 20mm long | 1 |
| 22a | Parallel key 8mm x 7mm x 20mm long | 1 |
| 23 | Bevel gear pinion | 1 |
| 24 | Circlip, 16mm external, pinion shaft (not shown) | 1 |
| 25 | Thrust washer | 1 |
| 26 | Bronze bush, 25mm ID x 30mm OD x 25mm long | 1 |
| 27 | End cap, bevel box | 1 |
| 28 | Hexagon socket capscrews, M16 x 20mm long | 3 |
| 29 | Collar | 1 |
| 30 | Extension shaft, bevel gear | 1 |
| 31 | Bearing bracket, extension shaft | 1 |
| 32 | Bronze bush, 20mm ID x 25mm OD x 25mm long | 2 |
| 33 | Hexagon socket capscrews, M6 x 20mm long | 2 |
| 34 | Digital readout | 1 |
| 35 | Square end shaft extension | 1 |
| 36 | Taper pin, No.1 | 1 |
| 37 | Extension shaft, vertical lock | 1 |
| 38 | Locking handle, M12 x 25mm, male | 1 |
| 39 | Main Frame | 1 |
| 40 | Cover, bevel box | 1 |
| 41 | Black plastic moulded hand wheel M12 | 1 |
| 42 | Top cover, bevel gear | 1 |
| 43 | Block for mounting outboard bearing housing | 1 |
| 44 | Stud M12 x 30mm long | 2 |
| 45 | Plain washer M12 | 2 |

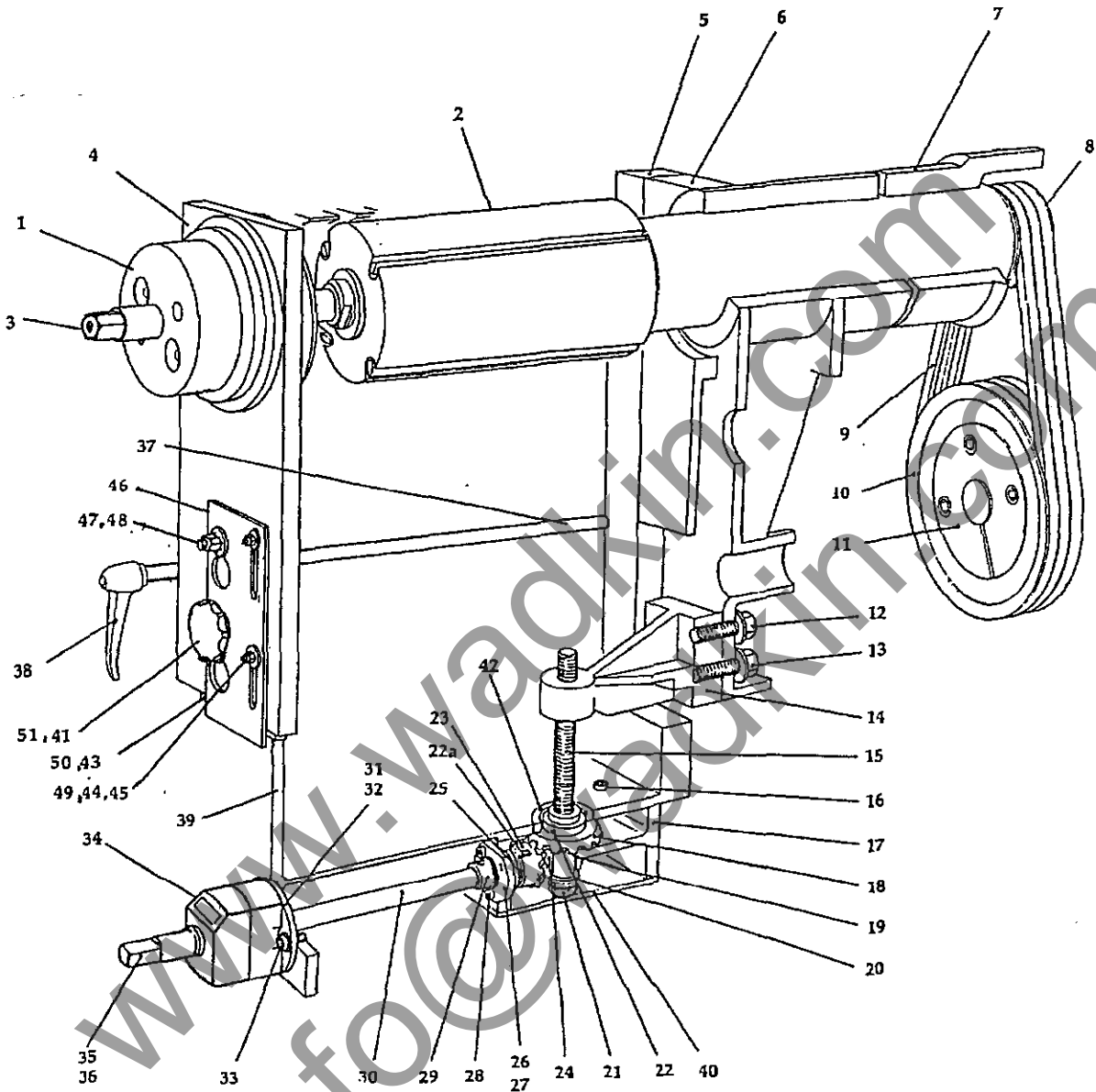

FIG 2- FIRST BOTTOM HEAD



2. FIRST BOTTOM HEAD (cont.)

| Ref. No. | Description | No. Off |
|----------|---|---------|
| 46 | Latch plate for outboard bearing | 1 |
| 47 | Collar nut WDS 404 - 205 M12 | 2 |
| 48 | Stud M12 x 70mm long | 2 |
| 49 | Nyloc nut M12 | 2 |
| 50 | Hexagon socket capscrew M12 x 30mm long | 4 |
| 51 | Counter sunk screw M12 x 16 long | 1 |

www.wadkin.com
info@wadkin.com

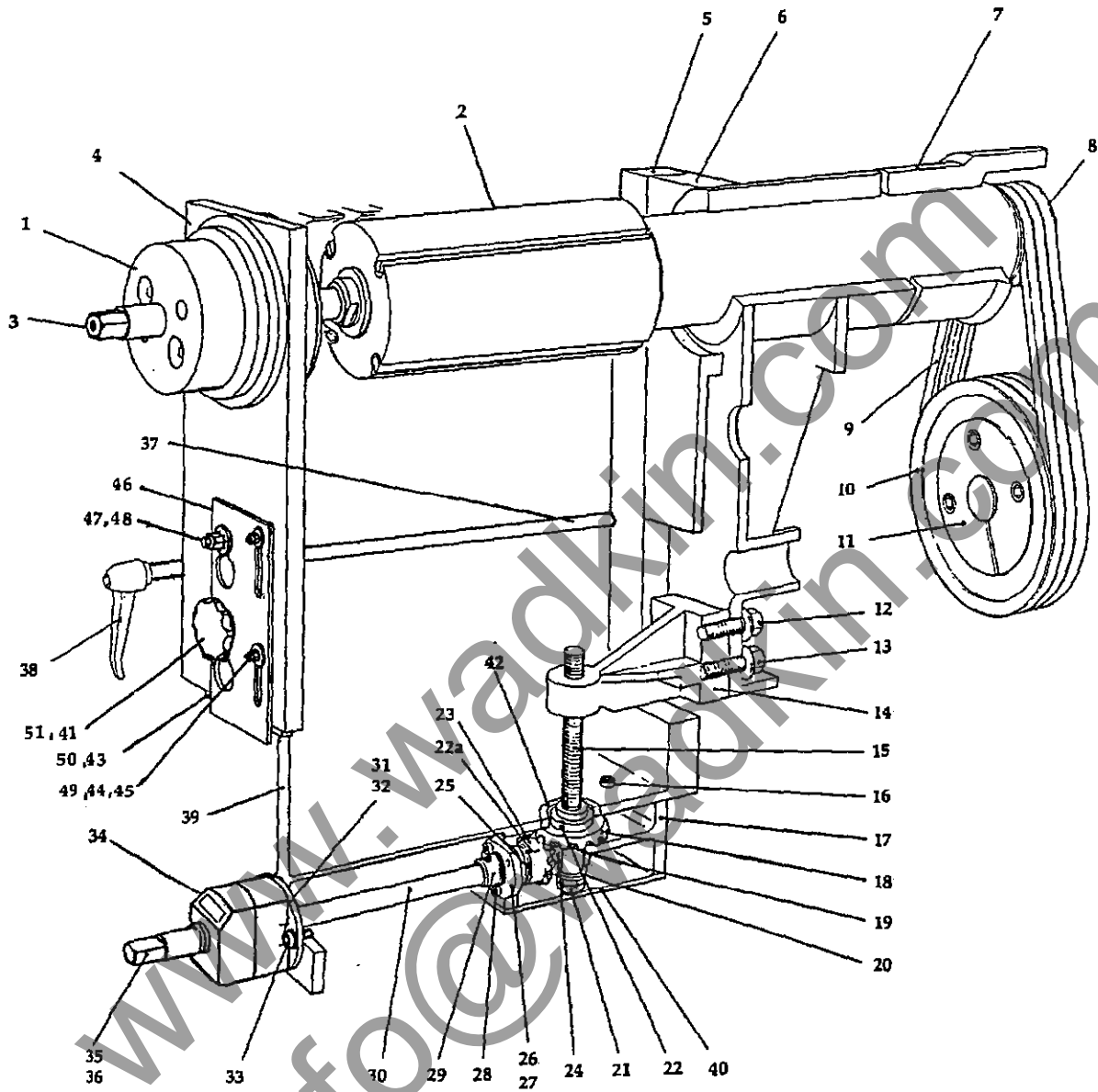

FIG 2. FIRST BOTTOM HEAD



3. FENCE SIDE HEAD CARRIAGE UNIT ADJUSTING MECHANISM

| Ref. No. | Description | No. Off |
|----------|---|---------|
| 1 | Carriage for fence side head spindle | 1 |
| 2 | Carriage extension for fence side head | 1 |
| 3 | Nut for vertical side head adjustment | 1 |
| 4 | Vertical adjusting screw | 1 |
| 5 | Mitre gear bracket for side head adjustment | 1 |
| 6 | Front horizontal shaft vertical adjustment | 1 |
| 7 | Front horizontal shaft lateral adjustment | 1 |
| 8 | Locking shaft or spindle barrel | 1 |
| 9 | Straight mitre bevel gear | 2 |
| 10 | Clamping block for horizontal movement | 1 |
| 11 | Mitre gear through shaft for rise and fall and Vee Belt Drive | 1 |
| 12 | Calibrated dial for traverse screw | 2 |
| 13 | Stop for rise and fall screw | 1 |
| 14 | Nut for lateral movement | 1 |
| 15 | Collar for horizontal shaft | 1 |
| 16 | Hexagon socket grub screw M6 x 8mm long | 1 |
| 17 | Hexagon socket capscrew M8 x 25mm long | 2 |
| 18 | Hexagon socket grubscrew M8 x 8mm long | 2 |
| 19 | Gaco 'O' ring RMO 246 24 | 2 |
| 20 | KEY 5mm x 5mm x 20mm | 3 |
| 21 | Hexagon socket capscrew M8 x 35mm long | 2 |
| 22 | Hexagon socket grubscrew M6 x 6mm long | 2 |
| 23 | Loose collar \varnothing 20 | 2 |
| 24 | Taper pin | 2 |
| 25 | Ina thrust washer AS 2035 | 1 |
| 26 | Tension pin \varnothing 6 | 2 |
| 27 | Hexagon head setscrew M8 x 60mm long | 2 |
| 28 | Grease nipple NA 5799 | 2 |
| 29 | Plain washer M8 | 2 |
| 30 | Hexagon head setscrew M10 x 80mm long | 1 |
| 31 | Plain washer M10 | 1 |
| 32 | Nut M10 | 1 |
| 33 | M12 Self locking nut | 1 |
| 34 | INA Thrust bearing AXK 2542 | 2 |
| 35 | INA Thrust washer AS 2542 | 2 |
| 36 | INA Thrust washer LS 2542 | 2 |
| 37 | Notched nut M24 x 1.5 | 2 |
| 38 | Hexagon head setscrew M10 x 20mm long | 1 |
| 39 | Large plain washer M10 | 1 |
| 40 | Stud M12 x 70mm long | 1 |
| 41 | Locking handle M12 x 25mm male | 2 |
| 42 | Brass pad | 1 |
| 43 | Tension pin \varnothing 4 | 1 |
| 44 | Hexagon socket capscrew M10 x 45mm long (carriage extension fastening to carriage slide) | 4 |
| 45 | Front horizontal shaft vertical adjustment | 1 |
| 46 | Square end shaft extension | 2 |
| 47 | Taper pin | 2 |
| 48 | 'SIKO' Digital readout | 2 |
| 49 | Front horizontal shaft lateral adjustment | 1 |
| 50 | Guard for gear bracket | 1 |



ILLUSTRATED PARTS LIST

SECTION

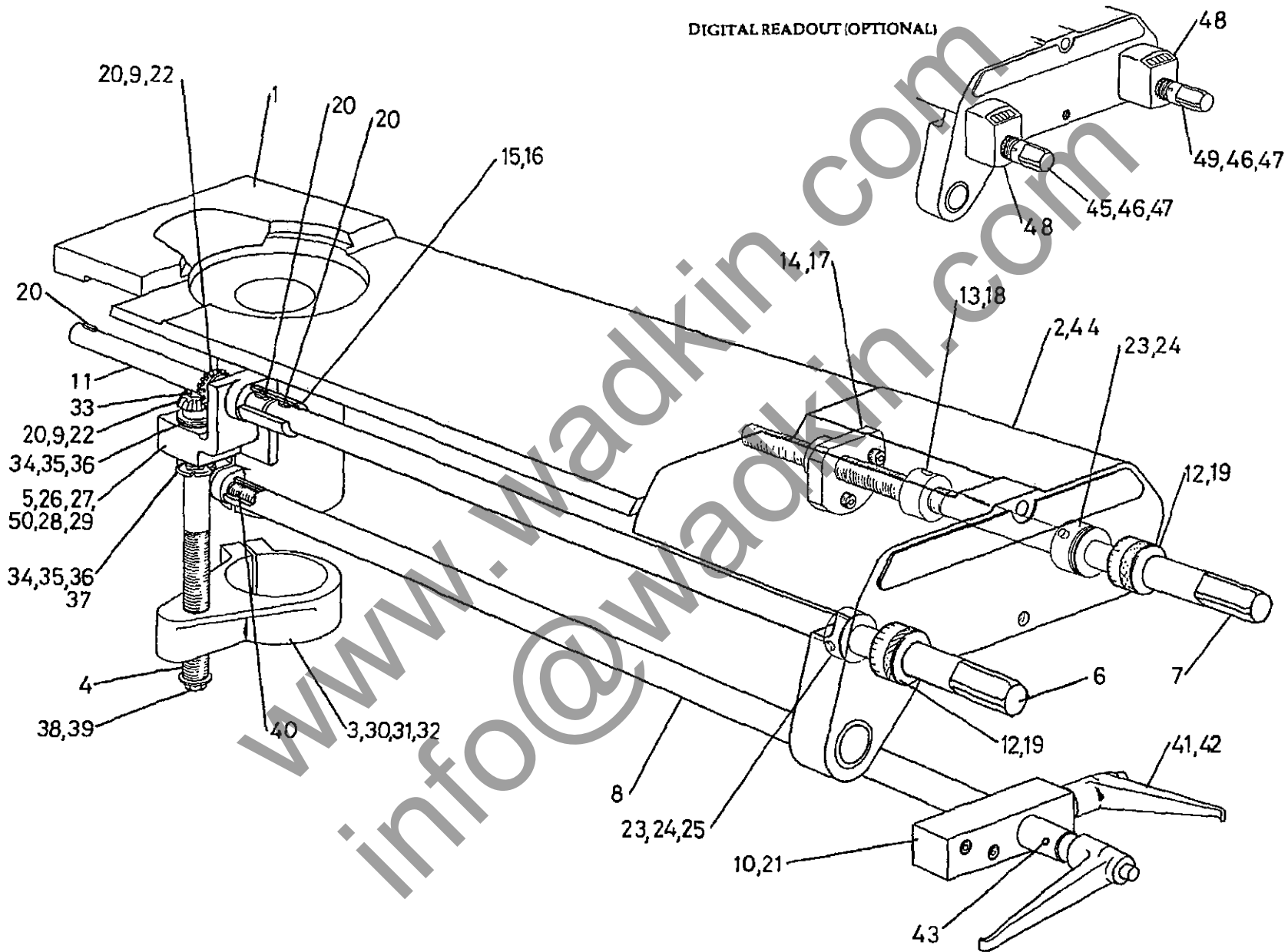

FIG 3 FENCE SIDE HEAD CARRIAGE UNIT ADJUSTING MECHANISM

4. TOP HEAD POWER RISE AND FALL

| Ref. No. | Description | No. Off |
|----------|---|---------|
| 1 | Socket head capscrew M12 x 30mm long | 4 |
| 2 | Plain washer M16 | 1 |
| 3 | Slide strip | 1 |
| 4 | Top head vertical slide | 1 |
| 5 | Vertical rise and fall screw | 1 |
| 6 | Nut for rise and fall screw | 1 |
| 7 | Hexagon head setscrew M8 x 25mm long | 2 |
| 8 | Top cover | 1 |
| 9 | Hexagon socket capscrew M6 x 8mm long | 4 |
| 10 | Bevel gear | 1 |
| 11 | Worm gear | 1 |
| 12 | Bearing 'SKF' 6204 RS | 2 |
| 13 | Dog clutch | 1 |
| 14 | External circlip 16mm dia. | 2 |
| 15 | Bronze bush 20mm O/D x 16mm I/D x 16mm long | 2 |
| 16 | Tension pin 6mm dia. x 32mm long | 1 |
| 17 | Gearbox / clutch housing | 1 |
| 18 | Clutch spacer washer | 2 |
| 19 | External circlip 30mm dia. | 2 |
| 20 | Thrust washer 'INA' AS 2542 | 2 |
| 21 | Thrust bearing 'INA' AXK 2542 | 2 |
| 22 | Shaft washer 'INA' WS 2542 | 2 |
| 23 | Locknut M16 | 2 |
| 24 | Bronze bush 30mm O/D x 25mm I/D x 20mm long | 1 |
| 25 | Hexagon socket grub screw M6 x 10mm long | 1 |
| 26 | Clutch location arm | 1 |
| 27 | Clutch adjusting shaft | 1 |
| 28 | Spring for spindle lock | 1 |
| 29 | Steel ball 10mm dia. | 1 |
| 30 | Locking handle M10 x 25mm male | 1 |
| 31 | Parallel key 8mm x 7mm x 14mm long | 1 |
| 32 | Bronze bush 35mm O/D x 30mm I/D x 20mm long | 1 |
| 33 | Bevel gear | 1 |
| 34 | Parallel key 5mm x 5mm x 20mm long | 1 |
| 35 | Main frame | 1 |
| 36 | Bearing bracket | 1 |
| 37 | Bronze bush 25mm O/D x 20mm I/D x 15mm long | 2 |
| 38 | 'SIKO' digital readout 0902E 2mm | 1 |
| 39 | Hexagon socket capscrew M6 x 20mm long | 2 |
| 40 | Plain washer M6 | 2 |
| 41 | Square end shaft extension | 1 |
| 42 | Taper pin No. 1 | 1 |
| 43 + | Compression spring | 1 |
| 44 | External circlip 25mm dia. | 1 |
| 45 | Notch nut M24 x 1.5 mm | 1 |

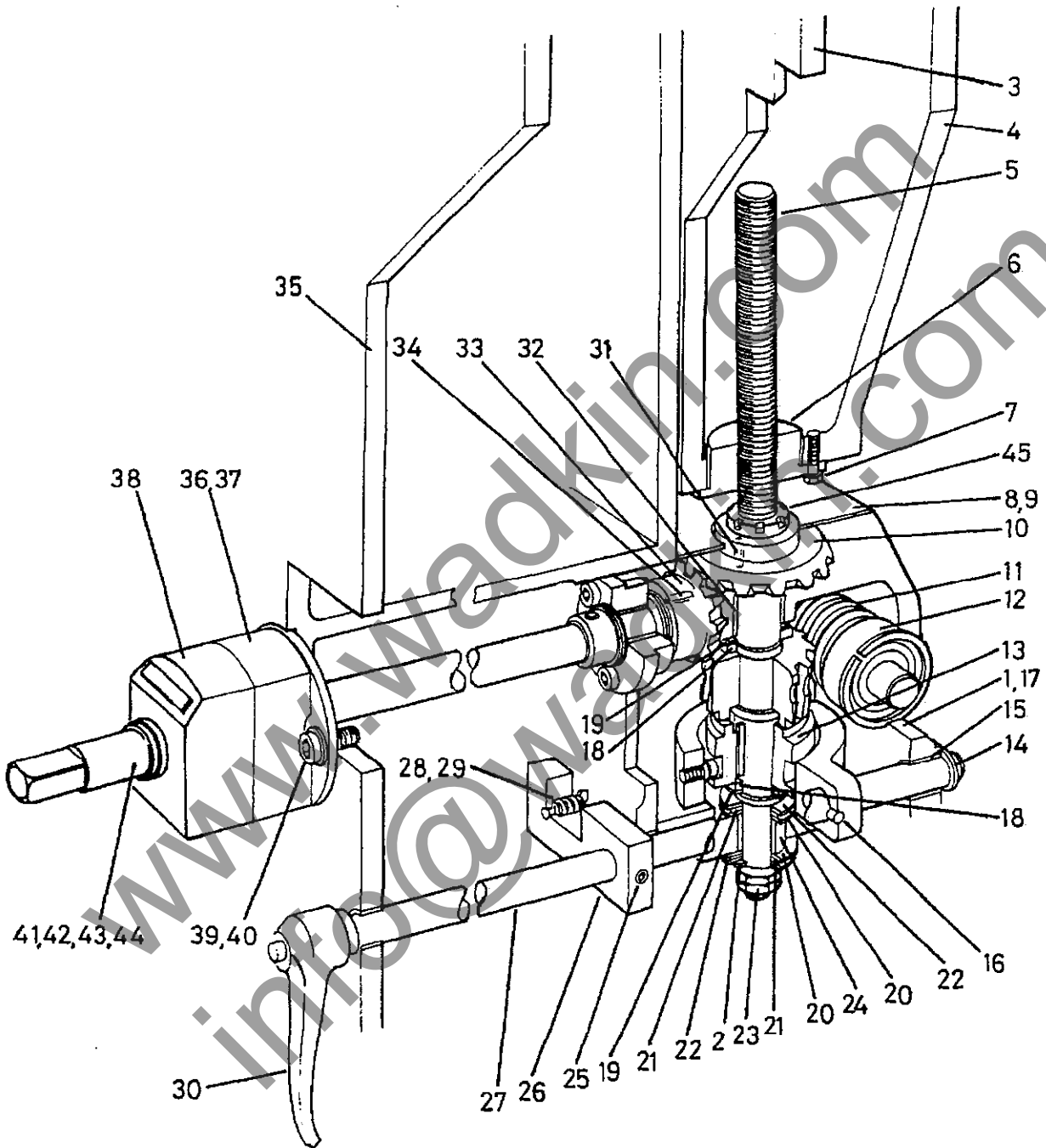

FIG 4 TOP HEAD POWER RISE AND FALL

4. TOP HEAD POWER RISE AND FALL (cont....)

| Ref. No. | Description | No. Off |
|----------|---|---------|
| 46 | Clutch yoke | 1 |
| 47 | Adjusting shaft | 1 |
| 48 | Hexagon socket capscrew M6 x 10mm long | 2 |
| 49 | Bottom cover | 1 |
| 50 | Parallel key 8mm x 7mm x 32mm long | 1 |
| 51 | Worm wheel | 1 |
| 52 | Bronze bush 25mm O/D x 20mm I/D x 25mm long | 1 |
| 53 | Thrust bearing 'INA' AXK 2035 | 2 |
| 54 | Thrust washer 'INA' AS 2035 | 4 |
| 55 | End cap | 1 |
| 56 | Hexagon socket capscrew M6 x 20mm long | 3 |
| 57 | Internal circlip 47mm dia. | 2 |
| 58 | Collar 32mm O/D x 20mm I/D x 14mm | 1 |
| 59 | Hexagon socket grub screw M6 x 6mm long | 1 |
| 60 | Hexagon socket capscrew M8 x 16mm long | 4 |
| + | Not illustrated | |

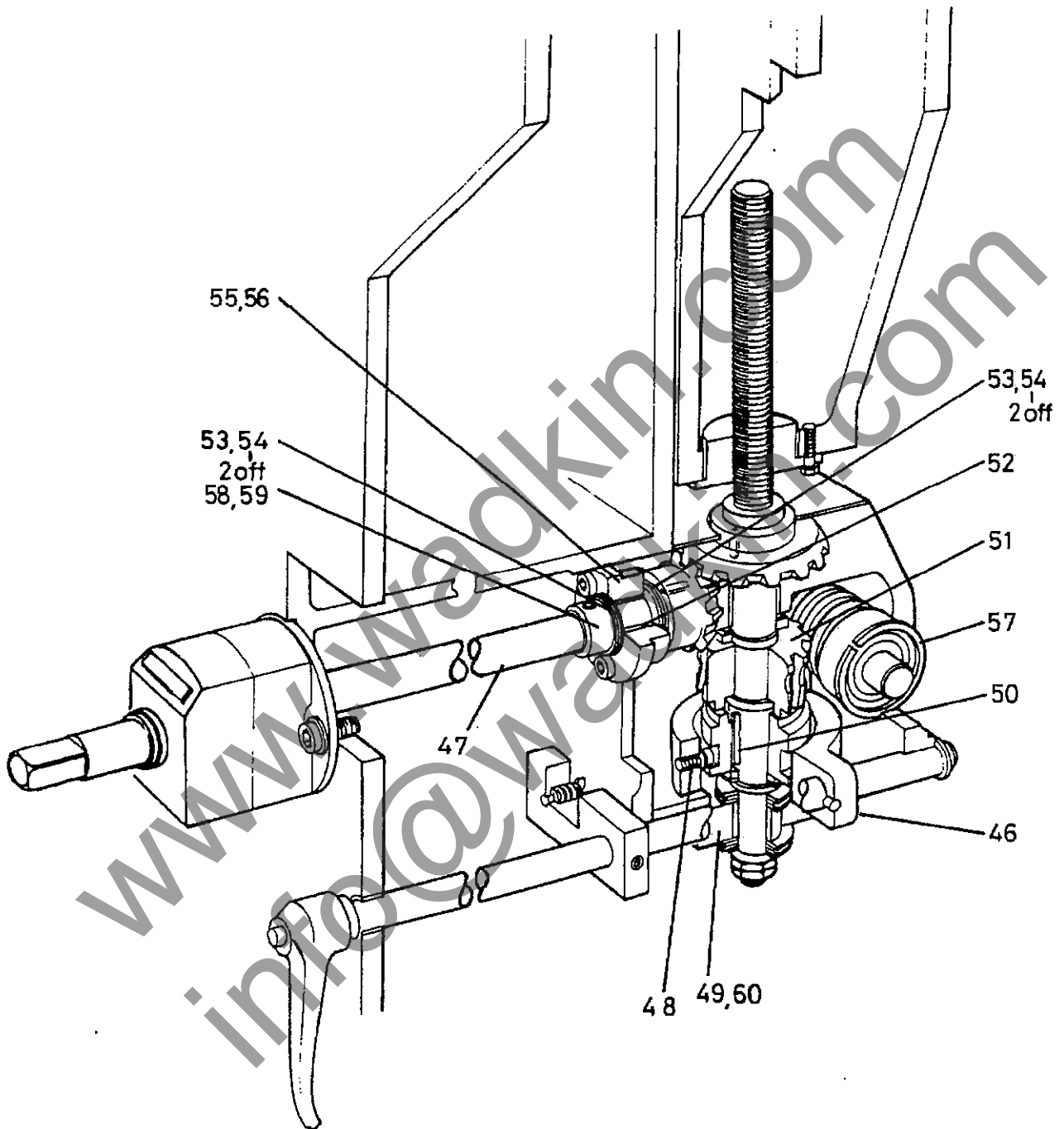

FIG 4 TOP HEAD POWER RISE AND FALL



5. OUTBOARD BEARING - SECOND BOTTOM HEAD

| Ref. No. | Description | No Off |
|----------|---|--------|
| 1 | Protective ring for hydrogrip sleeve | 1 |
| 2 | Locknut for outboard bearing | 1 |
| 3 | Bearing spacer | 2 |
| 4 | Disc spring 99mm O/D x 70.5mm I/D x 1mm | 2 |
| 5 | End cap for outboard bearing housing | 1 |
| 6 | R.H.P. grease packed bearing 6211-TB-EP7 | 1 |
| 7 | Outboard bearing housing | 1 |
| 8 | Drive key | 1 |
| 9 | Hexagon socket capscrew M3 x 12mm long | 1 |
| 10 | Hexagon socket capscrew M5 x 12mm long | 2 |
| 11 | Hexagon socket cap screw M6 x 12mm long | 8 |
| 12 | ETP sleeve (less front plate) | 1 |
| 13 | Grease nipple) Items only supplied | 1 |
| 14 | Pressure release valve) With E.T.P. sleeve | 1 |
| 15 | Hand wheel M8 threaded | 2 |
| 16 | Collar nut WDS 404-204 M12 | 2 |
| 17 | Taper dowel 12 x 40 | 2 |
| 18 | Shoulder screw | 2 |
| 19 | 'C' washer | 2 |
| 20 | Stud M12 x 70mm long | 2 |

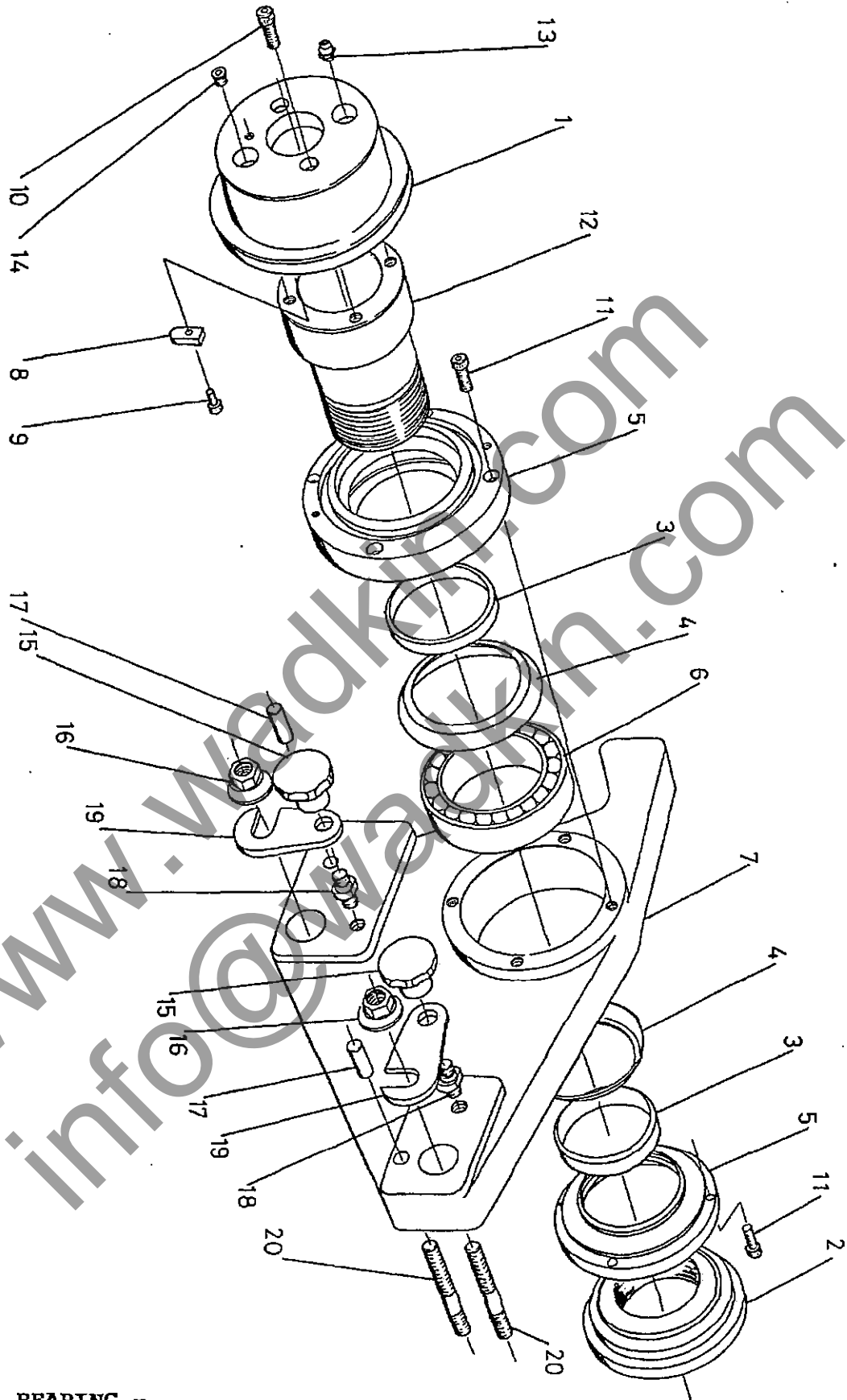

FIG 5 OUTBOARD BEARING -
SECOND BOTTOM HEAD

6. PAD PRESSURE AFTER TOP HEAD

| Ref. No. | Description | No. Off |
|----------|---|--|
| 1 | Cover for top head pressure spring | 1 |
| 2 | Nut for top head pressure adjustment | 1 |
| 3 | Pointer support first top head | 1 |
| OR | pointer support second top head | 1 |
| 4 | Wear strip | 1 |
| 5 | Saddle for top head pressure | 1 |
| 6 | 0-130mm Metric scale | 1 |
| 7 | Pointer | 1 |
| 8 | Screw for top head pressure adjustment | 1 |
| 9 | Bracket for mounting top head pressure pad | 1 |
| 10 | Cross tenon | 1 |
| 11 | Slide for top head pressure | 1 |
| 12 | Hexagon head setscrew | 4 |
| 13 | Hexagon socket grubscREW M6 x 6mm long | 1 |
| 14 | Hexagon socket capscrew M10 x 16mm long | 2 |
| 15 | Hexagon socket capscrew M10 x 50mm long | 2 |
| 16 | Hexagon socket capscrew M6 x 10mm long | 2 |
| 17 | Compression spring 'Flexo' 283816 | 1 |
| 18 | Thrust washer 'INA AS 1226 | 2 |
| 19 | Locknut M12 | 2 |
| 20 | Taper pin | 2 |
| 21 | Handwheel M12 | 1 |
| 22 | Helicoil insert M12 | 1 |
| 23 | Tee nut WDS 664203 | 2 |
| 24 | Stud M10 x 55mm long | 2 |
| 25 | Nut M10 | 2 |
| 26 | Plain large washer M10 | 2 |
| 27 | Hexagon socket capscrew M8 x 20mm long | 2 |
| 28 | Collar | 1 |
| 29 | Pad pressure shoe | |
| OR | Pad pressure shoe for splitting/counter profiling | { for machine with one top head only |
| OR | Pad pressure shoe | |
| | Pad pressure shoe for ø 125 cotting circle | { for machine with two or more top heads |
| OR | Pad pressure shoe for soft pads (optional) | |

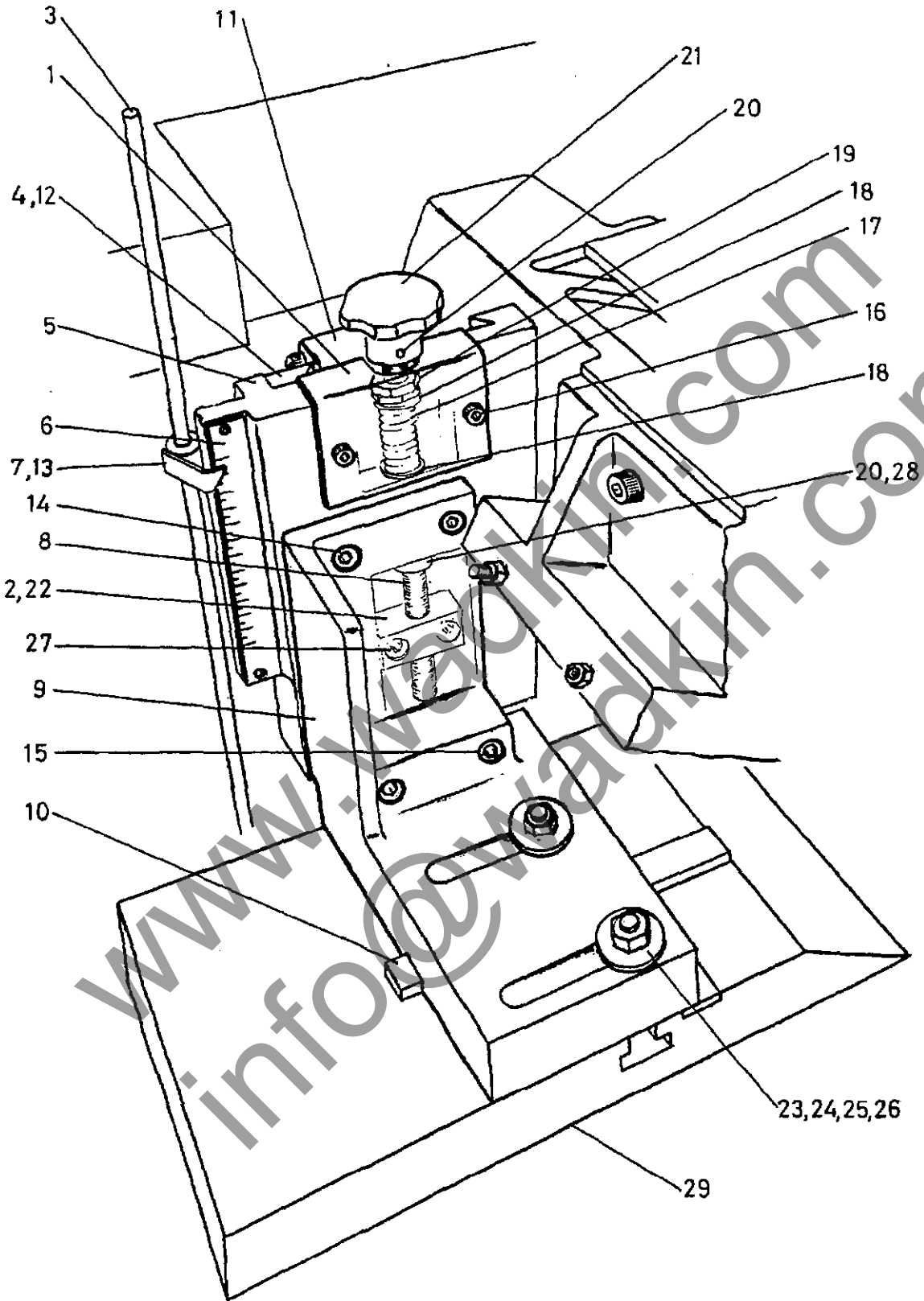

FIG 6 TOP HEAD PRESSURE PAD



7. SIDE PRESSURE UNIT BEFORE NEAR SIDE HEAD

| Ref. N ^o . | Description | No. Off |
|-----------------------|--|---------|
| 1 | Spring tension screw | 1 |
| 2 | Side pressure housing | 1 |
| 3 | Spring | 1 |
| 4 | Plunger | 1 |
| 5 | Skid pressure shoe | 1 |
| 6 | Taper pin | 1 |
| 7 | Dowel dia 10 x 25 long | 1 |
| 8 | Bronze bush 25ODmm, 20mmID x 15mm long | 1 |
| 9 | Pivot pin | 1 |
| 10 | Stud M12 x 55mm long | 2 |
| 11 | Hexagon nut M12 | 2 |
| 12 | Plain washer M12 | 2 |
| 13 | Hexagon socket capscrews, M6 x 12mm long | 3 |
| 14 | Plain washer M6 | 3 |
| 15 | Carrier for bottom head guard | 1 |
| 16 | Pad | 1 |
| 17 | Sliding wooden guard | 1 |
| 18 | Knob | 1 |
| 19 | Screwed stud | 1 |

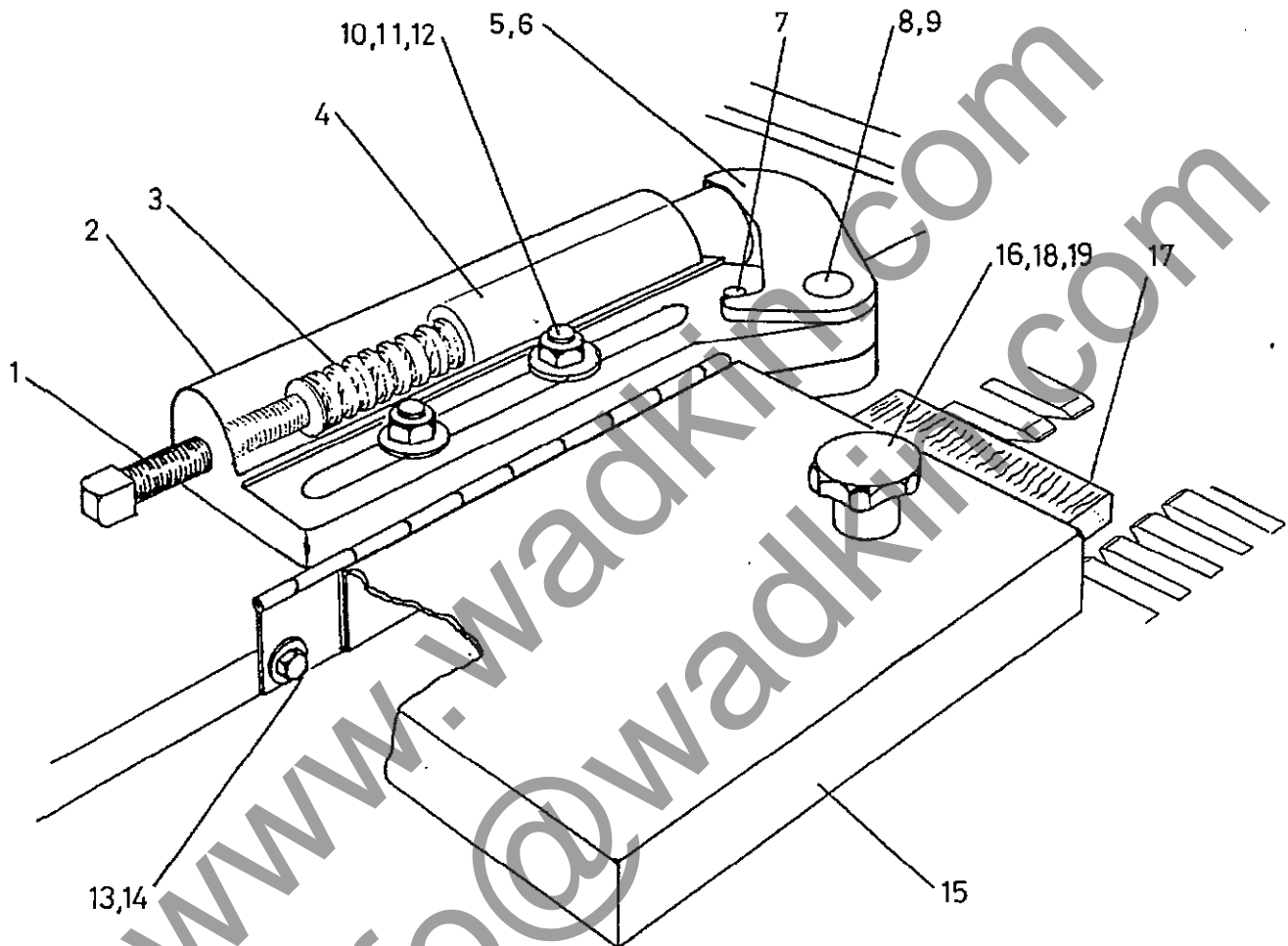

FIG 7 SIDE PRESSURE BEFORE NEAR SIDE HEAD AND GUARD OVER FIRST BOTTOM HEAD



8. TOP HEAD CHIPBREAKER MK III

| Ref. No. | Description | No. Off |
|----------|---|---------|
| 1 | Wear strip | 1 |
| 2 | Screw | 1 |
| 3 | Thumb nut WDS 614-204 | 1 |
| 4 | Hand knob | 1 |
| 5 | Cap for tension spring | 2 |
| 6 | Adjusting screw | 1 |
| 7 | Plate for adjusting screw | 1 |
| 8 | Swing for chipbreaker (front) | 1 |
| 9 | Stop for top head chipbreaker | 1 |
| 10 | Swing for chipbreaker (rear) | 1 |
| 11 | Shaft for chipbreaker pivot | 1 |
| 12 | Eye bolt | 1 |
| 13 | Hod for chipbreaker carrier | 1 |
| 14 | Adjusting screw for top chipbreaker | 3 |
| 15 | Baffle/spring housing | 3 |
| 16 | Block for spacing baffle | 3 |
| 17 | Shoe for chipbreaker | 3 |
| 18 | Pin of chipbreaker shoe pivot | 3 |
| 19 | Bracket for mounting chipbreaker shoe | 3 |
| 20 | Hexagon head setscrew M8 x 20mm long | 4 |
| 21 | Stud M12 x 50mm long | 2 |
| 22 | Large washer M12 | 2 |
| 23 | Nut M12 | 2 |
| 24 | Hexagon head grubscrew M6 x 20mm long | 4 |
| 25 | Locknut M6 | 4 |
| 26 | Hexagon socket capscrew M6 x 16mm long | 2 |
| 27 | Hexagon socket capscrew M12 x 30mm long | 4 |
| 28 | Collar 40mm OD x 25mm ID x 16mm wide | 1 |
| 29 | Disc springs 50mm OD x 25.4mm ID x 1.5 | 10 |
| 30 | Rod clevis festo SG M12 | 1 |
| 31 | Nut M12 | 1 |
| 32 | Lock screw M12 | 2 |
| 33 | Stud M12 x 65mm long | 6 |
| 34 | Washer M12 | 6 |
| 35 | Nut M12 | 6 |
| 36 | Hexagon head setscrew M6 x 30mm long | 3 |
| 37 | Hexagon socket grubscrew M6 x 10mm long | 3 |
| 38 | Oilite bronze bush 20mm OD x 16mm ID x 12mm long | 6 |
| 39 | Compression spring | 1 |
| 40 | Hexagon socket capscrew M10 x 60mm long | 6 |
| 41 | Compression spring 135mm long x 28.2 OD x 21.8 ID | 1 |
| 42 | Thrust washer INA AS 1226 | 2 |

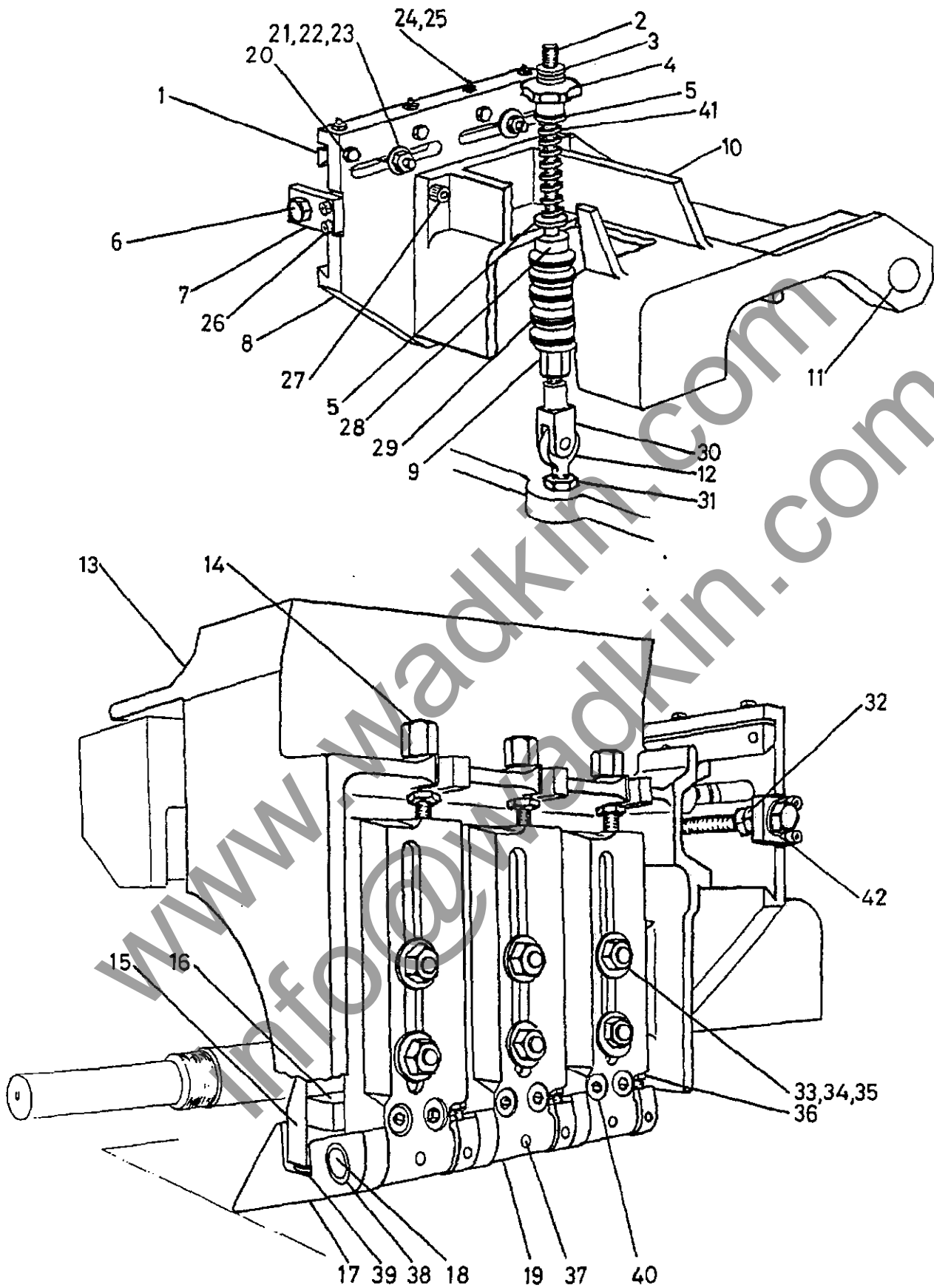

FIG 8 TOP HEAD CHIPBREAKER



9. OUTBOARD BEARING - FIRST BOTTOM HEAD

| Ref. No. | Description | No. Off |
|----------|--|---------|
| 1 | Protective ring for hydrogrip sleeve | 1 |
| 2 | Locknut for outboard bearing | 1 |
| 3 | Bearing spacer | 2 |
| 4 | Disc spring 99mm O/D x 70.5mm I/D x 1mm | 2 |
| 5 | End cap for outboard bearing housing | 1 |
| 6 | R.H.P. grease packed bearing 6211-TB-EP7 | 1 |
| 7 | Outboard bearing housing | 1 |
| 8 | Drive key | 1 |
| 9 | Hexagon socket capscrew M3 x12mm long | 1 |
| 10 | Hexagon socket capscrew M5 x12mm long | 2 |
| 11 | Hexagon socket capscrew M6 x12mm long | 4 |
| 12 | E.T.P sleeve (less front plate) | 1 |
| 13 | Grease nipple) Items only supplied | 1 |
| 14 | Pressure release valve) with ETP sleeve | 1 |

www.wadkin.com
info@wadkin.com

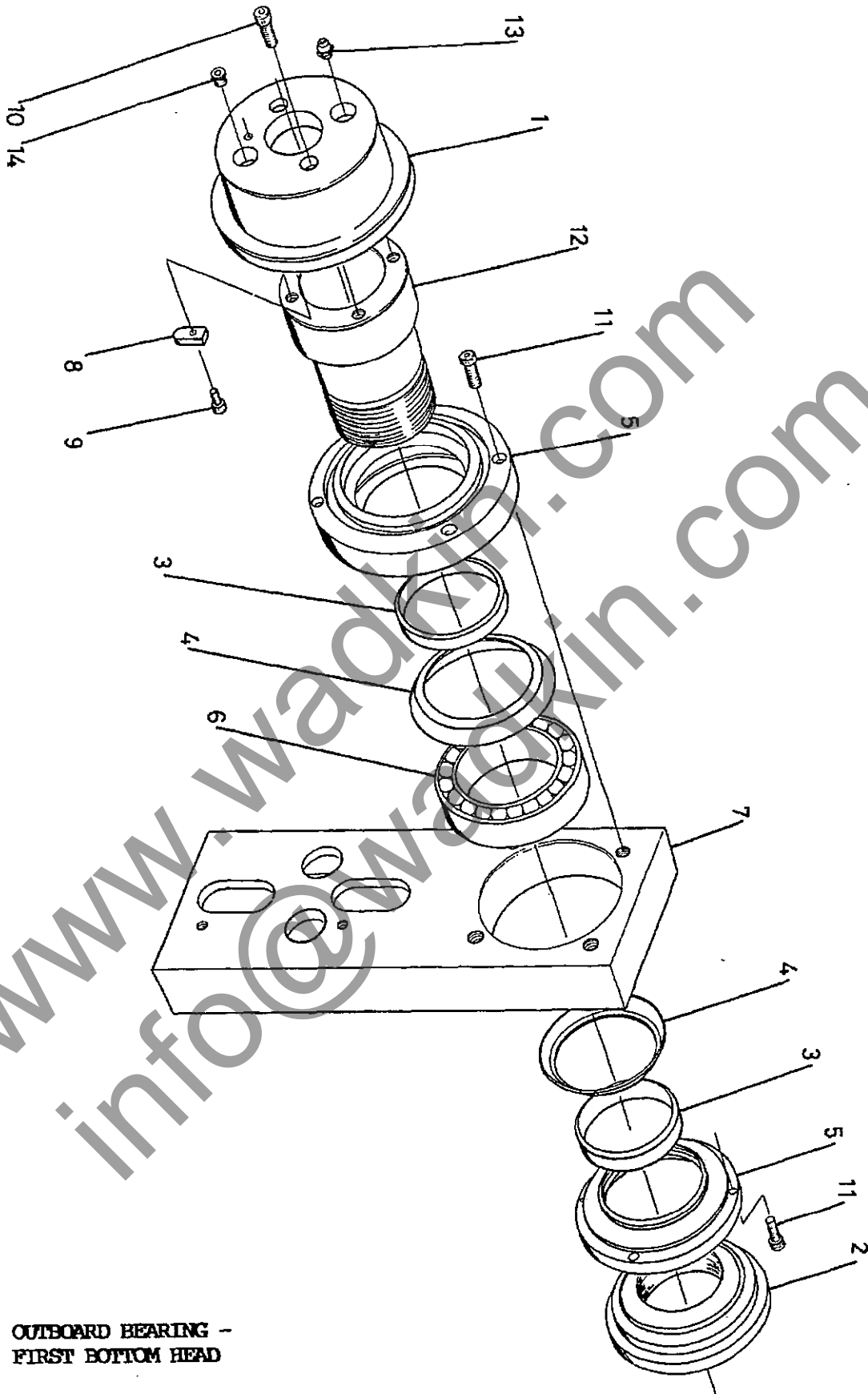

FIG. 9 OUTBOARD BEARING -
FIRST BOTTOM HEAD

10. OUTBOARD BEARING - MK II TOP HEADS

| Ref. No. | Description | No Off |
|----------|--|--------|
| 1 | Protective ring for hydrogrip sleeve | 1 |
| 2 | Locknut for outboard bearing | 1 |
| 3 | Bearing spacer | 2 |
| 4 | Disc spring 99mm O/D x 70.5mm I/D x 1mm | 2 |
| 5 | End cap for outboard bearing housing | 1 |
| 6 | R.H.P. grease packed bearing 6211-TB-EP7 | 1 |
| 7 | Outboard bearing housing | 1 |
| 8 | Drive key | 1 |
| 9 | Hexagon socket capscrew M3 x 12mm long | 1 |
| 10 | Hexagon socket capscrew M5 x 12mm long | 2 |
| 11 | Hexagon socket cap screw M6 x 12mm long | 8 |
| 12 | ETP sleeve (less front plate) | 1 |
| 13 | Grease nipple | 1 |
| 14 | Pressure release valve | 1 |
| 15 | Hand wheel M8 threaded | 2 |
| 16 | Collar nut WDS 404-204 M12 | 2 |
| 17 | Taper dowel 12 x 40 | 2 |
| 18 | Shoulder screw | 2 |
| 19 | 'C' washer | 2 |
| 20 | Stud M12 x 70mm long | 2 |

www.wadkin.com
info@wadkin.com

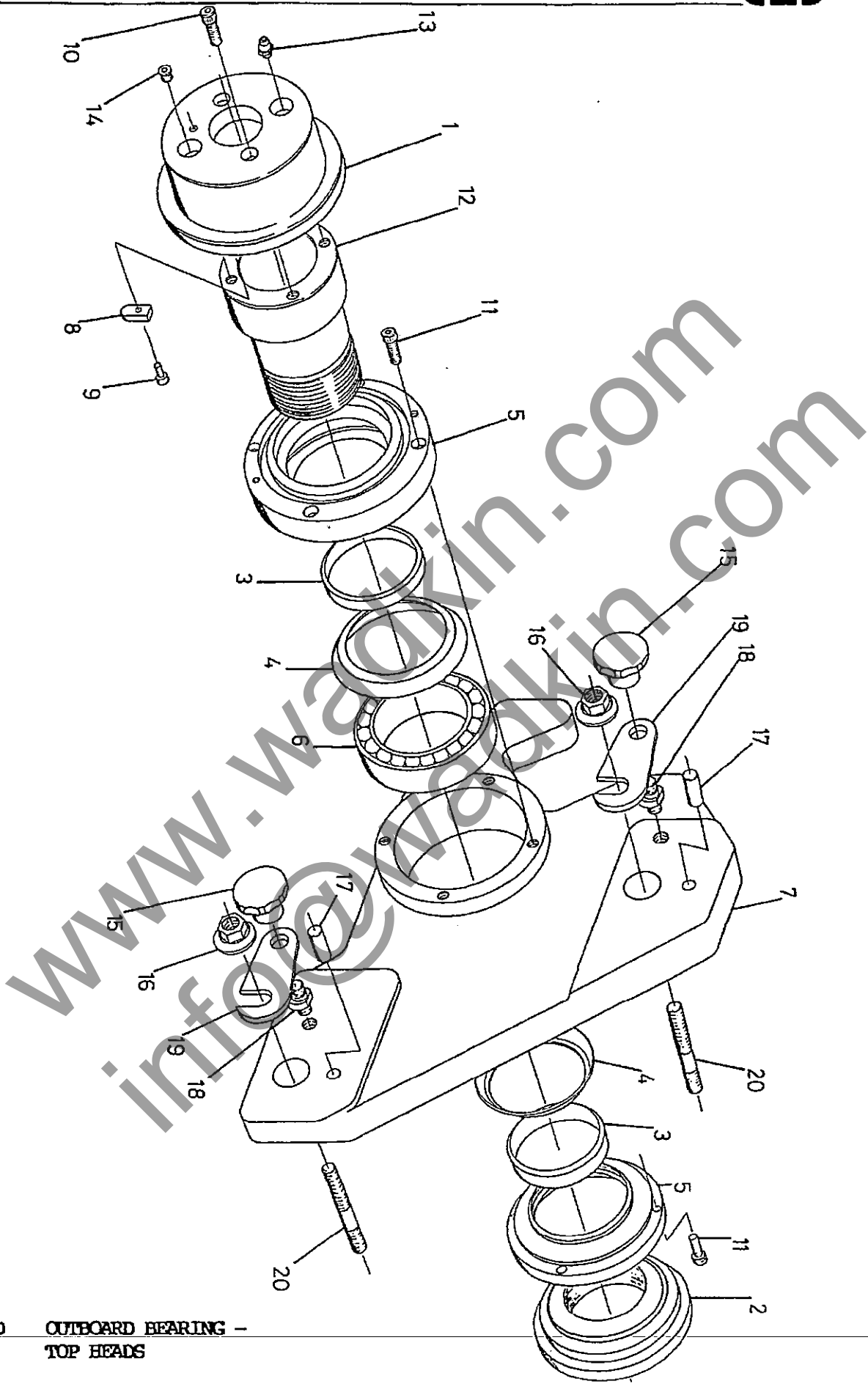

FIG 10 OUTBOARD BEARING - TOP HEADS



11. SIMPLABELT VARIABLE SPEED DRIVE UNIT

| Ref. No. | Description | No.Off |
|----------|---|--------|
| 1 | Front drive cover | 1 |
| 2 | Simplatroll hand wheel HA15 | 1 |
| 3 | Mounting plate for hand adjuster | 1 |
| 4 | Cover for drive shaft pulleys | 1 |
| 5 | Pulley, Driver, Fenner 031Z-0125 | 1 |
| 6 | Vee belt Fenner SPZ 1320 | 5 |
| 7 | Pulley driven Fenner 031Z 0335 | 1 |
| 8 | Back plate for drive shaft cover | 1 |
| 9 | Rear drive cover | 1 |
| 10 | Mechanically adjustable pulley (motor driven) | 1 |
| 11 | Locking plate | 1 |
| 12 | Tightening screw | 1 |
| 13 | Disc washer or nut | 1 |
| 14 | Spring loaded pulley (driven shaft) | 1 |
| 15 | Locking plate | 1 |
| 16 | Disc washer or nut | 1 |
| 17 | Tightening screw | 1 |
| 18 | External circlip 45mm | 2 |
| 19 | SKF or RHP bearing 6009-2Z | 2 |
| 20 | Drive shaft | 1 |
| 21 | Internal circlip 75mm | 2 |
| 22 | Toothed belt, Simplabelt 47/1060 | 1 |
| 23 | Guard for bearing bracket | 1 |
| 24 | Simplatroll dial S8ON24I-1 | 1 |
| 25 | Taperlock bush 1610 - 30mm bore | 1 |
| 26 | Taperlock bush 2517 - 28mm bore | 1 |
| 27 | Adjuster | 1 |
| 28 | Bearing bracket | 1 |

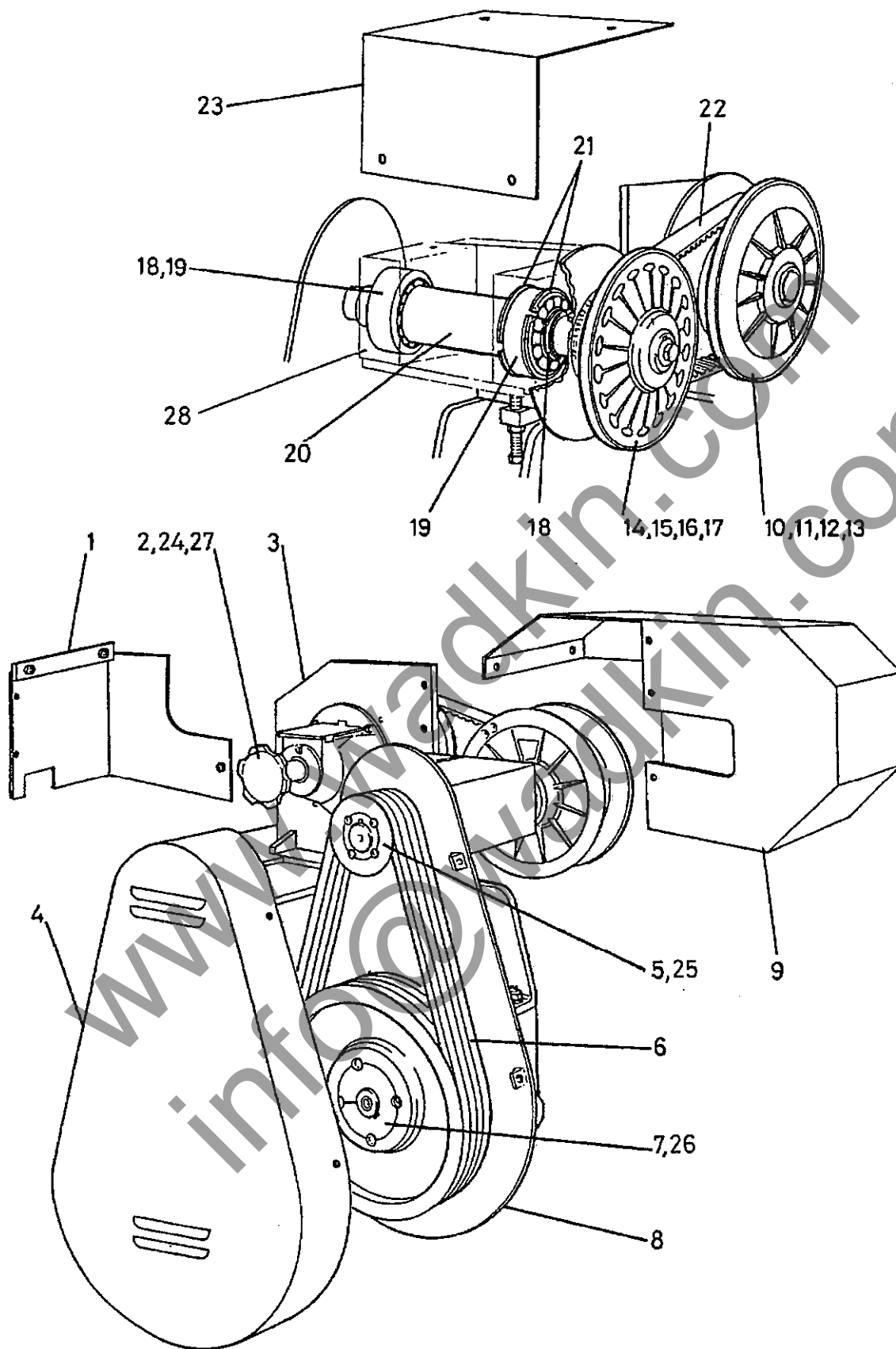

FIG 11 VARIABLE SPEED DRIVE



12. FENCE SIDE HEAD SPINDLE UNIT - 40MM DIAMETER SQUARE SHOULDER

| Ref. No. | Description | No. Off |
|----------|---|---------|
| 1 | Locking nut | 1 |
| 2 | 40mm square shoulder fence side head spindle | 1 |
| 3 | Nut for spindle front bearing R.H. | 1 |
| 4 | Nut for spindle barrel front bearing | 1 |
| 5 | Spacer rings for bearings | 2 |
| *6 | R.H.P. paired bearings 7009 TDUF EP7 | 2 |
| 7 | Spindle pulley (refer to motor and drive belt data) | 1 |
| 8 | Pulley spigot for spindle | 1 |
| 9 | Hexagon head setscrew M12 x 40mm | 1 |
| 10 | Barrel housing | 1 |
| 11 | Parallel key 12mm x 8mm x 50mm long | 1 |
| * | 'Kluber' grease packed | |

www.wadkin.com
info@wadkin.com

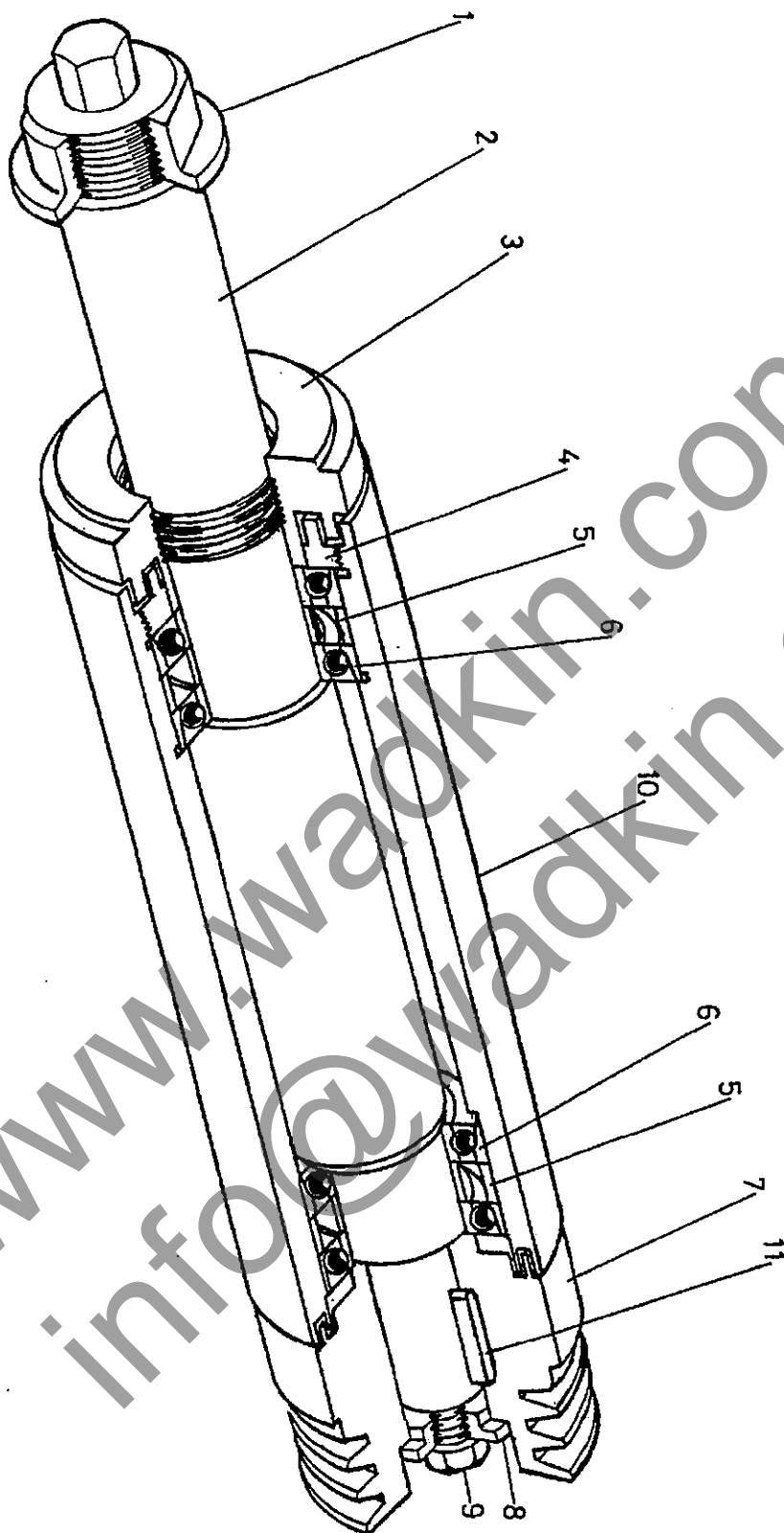

FIG 12 FENCE SIDE HEAD SPINDLE UNIT

**13. FENCE SIDE HEAD SPINDLE UNIT - 45mm, 50mm AND 1 13/16
DIAMETER SQUARE SHOULDER**

| Ref. No. | Description | No. Off |
|----------|---|---------|
| 1 | Locking nut | 1 |
| 2 | 45mm diameter square shoulder spindle | 1 |
| | or 50mm diameter square shoulder spindle | 1 |
| | or 1 13/16 diameter square shoulder spindle | 1 |
| 3 | Nut for spindle front bearing R.H | 1 |
| 4 | Nut for spindle barrel front bearing | 1 |
| 5 | Spacer rings for bearings | 2 |
| *6 | R.H.P. paired bearings 7009 TDUF EP7 | 2 |
| 7 | Spindle pulley (refer to motor and drive belt data) | 2 |
| 8 | Pulley spigot for spindle | 1 |
| 9 | Hexagon head setscrew M12 x 40mm | 1 |
| 10 | Barrel housing | 1 |
| 11 | Parallel key 12mm x 8mm x 50mm long | 1 |
| 12 | Bearing spacer | 1 |
| * | 'Kluber' grease packed | |

www.wadkin.com
info@wadkin.com

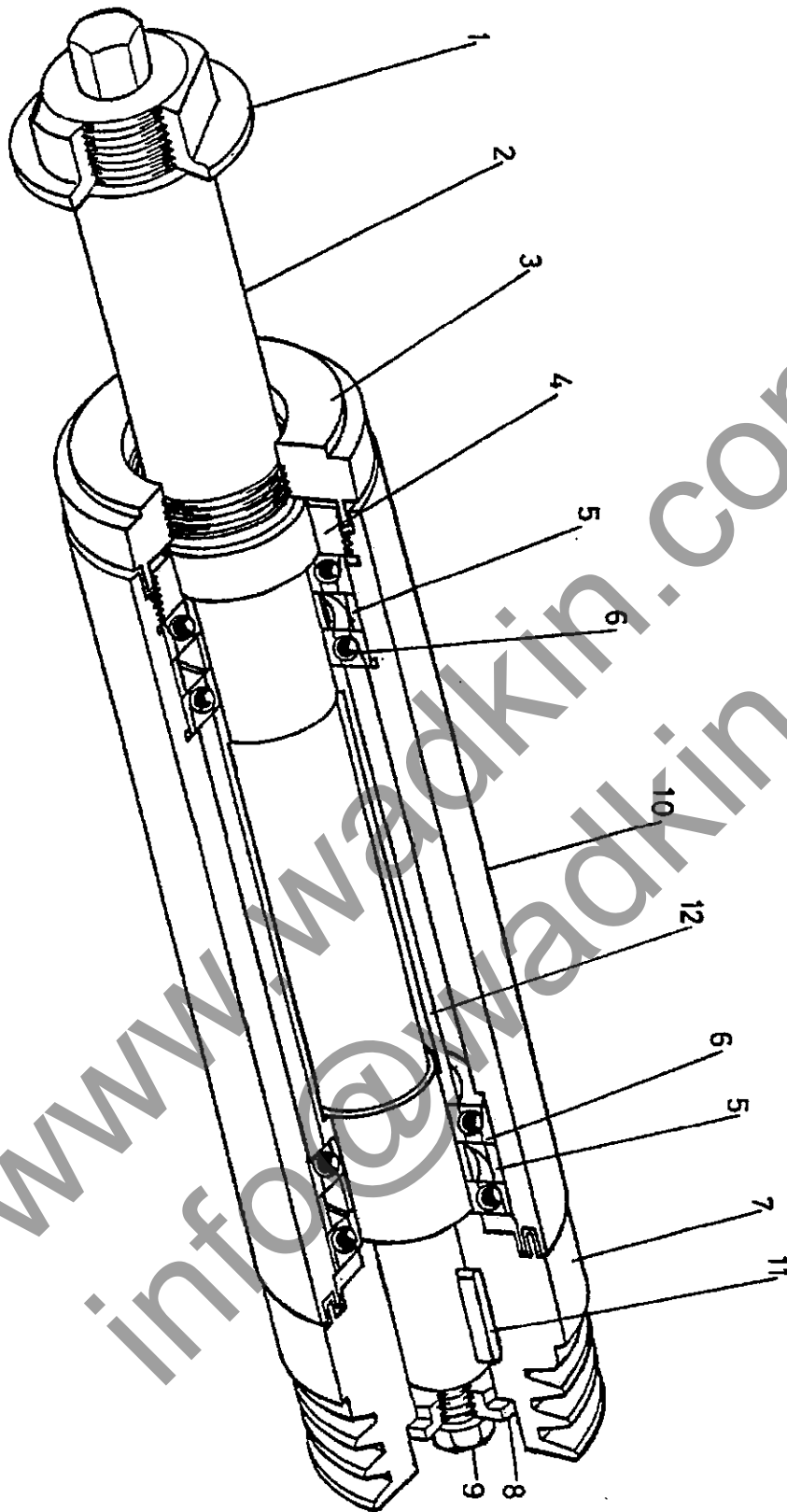

FIG 13 FENCE SIDE HEAD SPINDLE UNIT

14. NEAR SIDE HEAD SPINDLE UNIT - 40MM DIAMETER SQUARE SHOULDER

| Ref. No. | Description | No. Off |
|----------|---|---------|
| 1 | Locking nut | 1 |
| 2 | 40mm square shoulder near side head spindle | 1 |
| 3 | Nut for spindle front bearing L.H | 1 |
| 4 | Nut for spindle barrel front bearing | 1 |
| 5 | Bearing spacer rings | 2 |
| *6 | R.H.P. paired bearings 7009 TDUF EP7 | 2 |
| 7 | Spindle pulley (refer to motor and drive belt data) | 1 |
| 8 | Pulley spigot for spindle | 1 |
| 9 | Hexagon head setscrew M12 x 40mm | 1 |
| 10 | Barrel housing | 1 |
| 11 | Parallel key 12mm x 8mm x 50mm long | 1 |
| * | 'Kluber' grease packed | |

www.wadkin.com
info@wadkin.com

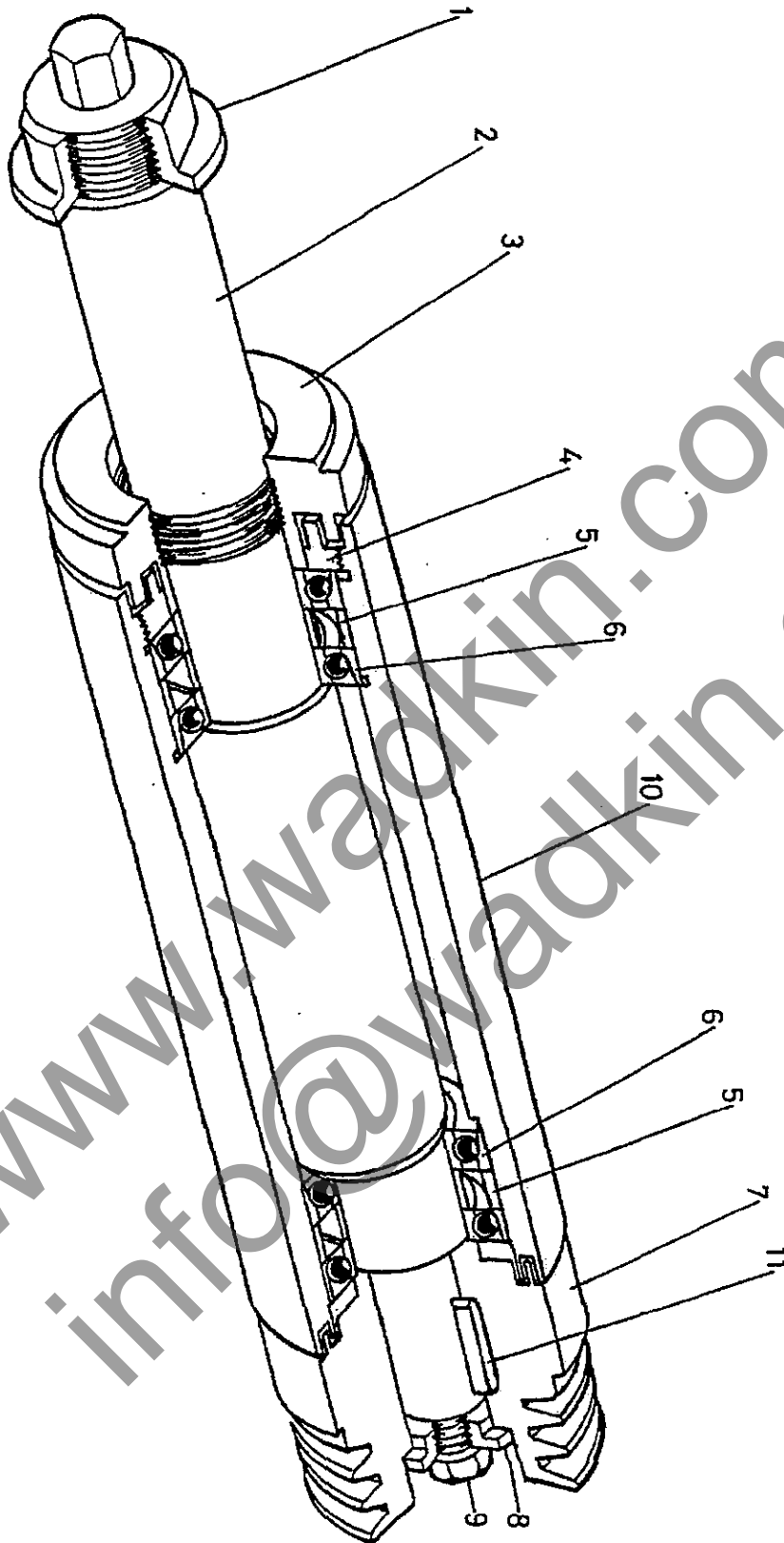

FIG 14 NEAR SIDE HEAD SPINDLE UNIT

15. NEAR SIDE HEAD SPINDLE UNIT — 45mm, 50mm AND 1 13/16
DIAMETER SQUARE SHOULDER

| Ref. No. | Description | No. Off |
|----------|---|---------|
| 1 | Locking nut | 1 |
| 2 | 45mm diameter square shoulder spindle | 1 |
| | or 50mm diameter square shoulder spindle | 1 |
| | or 1 13/16 diameter square shoulder spindle | 1 |
| 3 | Nut for spindle front bearing R.H | 1 |
| 4 | Nut for spindle barrel front bearing | 1 |
| 5 | Spacer rings for bearings | 1 |
| *6 | R.H.P paired bearings 7009 TDUF EP7 | 2 |
| 7 | Spindle pulley (refer to motor and drive belt data) | 2 |
| 8 | Pulley spigot for spindle | 2 |
| 9 | Hexagon head setscrew M12 x 40mm | 1 |
| 10 | Barrel housing | 1 |
| 11 | Parallel key 12mm x 8mm x 50mm long | 1 |
| 12 | Bearing spacer | 1 |

*'Kluber' grease packed

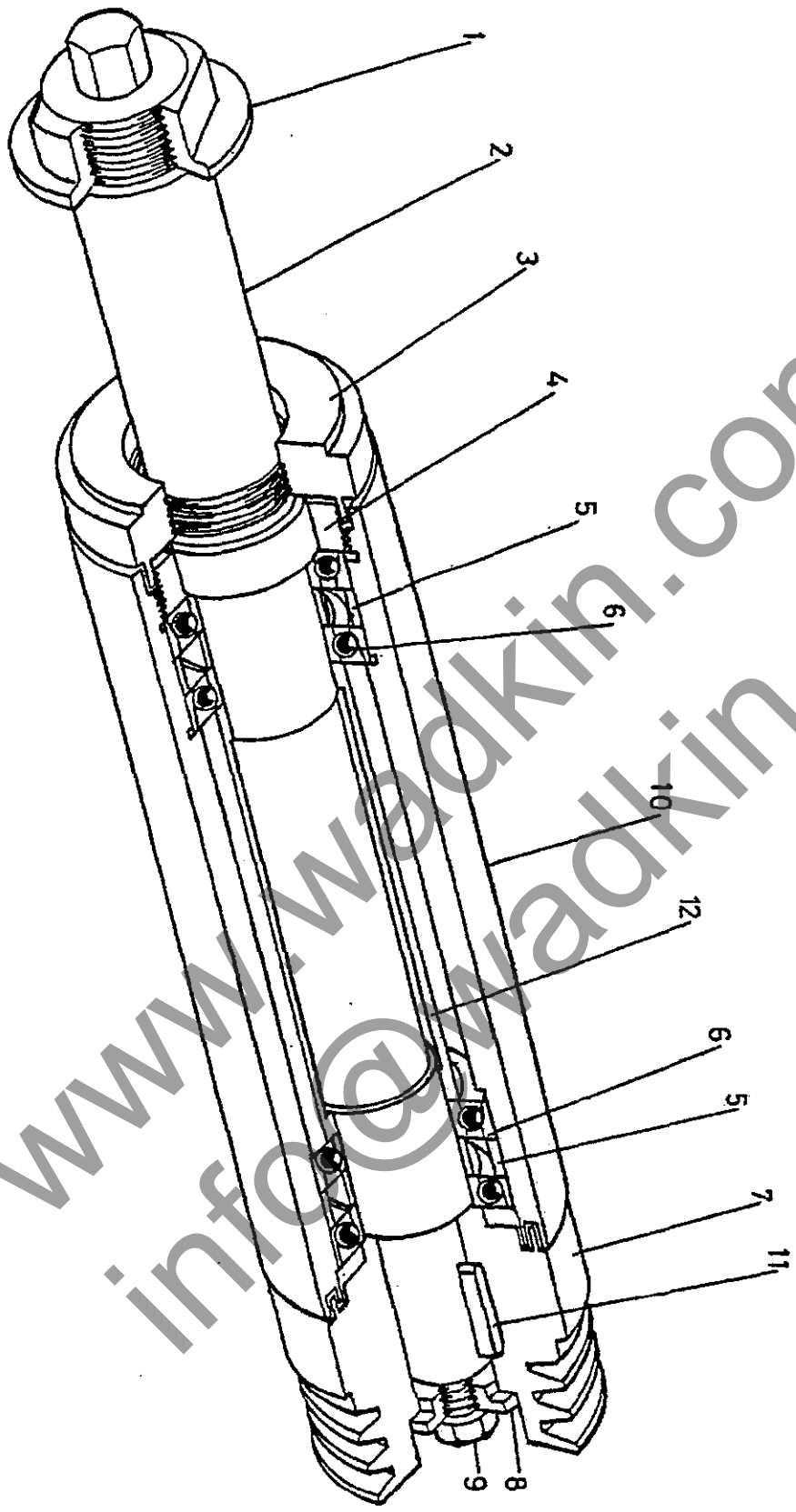

FIG 15 NEAR SIDE HEAD SPINDLE UNIT



16. TOP HEAD SPINDLE UNIT — 40MM DIAMETER SQUARE SHOULDER

| Ref. No. | Description | No. Off |
|----------|---|---------|
| 1 | Locking nut | 1 |
| 2 | 40mm square shoulder Top head spindle | 1 |
| 3 | Nut for spindle front bearing R.H. | 1 |
| 4 | Nut for spindle barrel front bearing | 1 |
| 5 | Spacer rings for bearings | 2 |
| *6 | R.H.P. paired bearings 7009 TDUF EP7 | 2 |
| 7 | Spindle pulley (refer to motor and drive belt data) | 1 |
| 8 | Pulley spigot for spindle | 1 |
| 9 | Hexagon head setscrew M12 x 40mm | 1 |
| 10 | Barrel housing | 1 |
| 11 | Parallel key 12mm x 8mm x 50mm long | 1 |

*'Kluber' grease packed

www.wadkin.com
info@wadkin.com

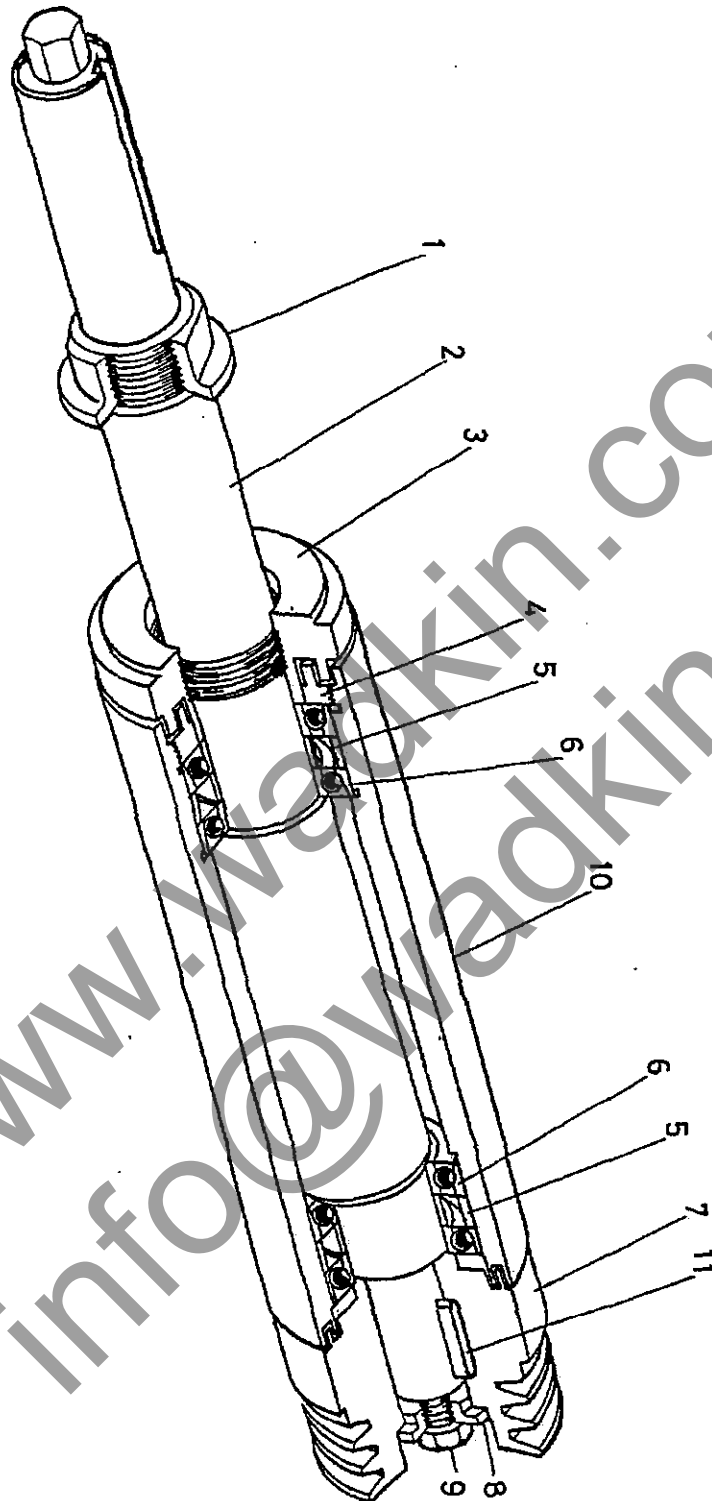

FIG 16 TOP HEAD SPINDLE UNIT



17. TOP HEAD SPINDLE UNIT - 45mm, 50mm AND 1 13/16 DIAMETER SQUARE SHOULDER

| Ref. No. | Description | No. Off |
|----------|---|---------|
| 1 | Locking nut | 1 |
| 2 | 45mm diameter square shoulder spindle | 1 |
| | or 50mm diameter square shoulder spindle | 1 |
| | or 1 13/16 diameter square shoulder spindle | 1 |
| 3 | Nut for spindle front bearing R.H. | 1 |
| 4 | Nut for spindle barrel front bearing | 1 |
| 5 | Spacer rings for bearings | 2 |
| *6 | R.H.P. paired bearings 7009 TDUF EP7 | 2 |
| 7 | Spindle pulley (refer to motor and drive belt data) | 2 |
| 8 | Pulley spigot for spindle | 1 |
| 9 | Hexagon head setscrew M12 x 40mm | 1 |
| 10 | Barrel housing | 1 |
| 11 | Parallel key 12mm x 8mm x 50mm long | 1 |
| 12 | Bearing spacer | 1 |
| * | 'Kluber' grease packed | |

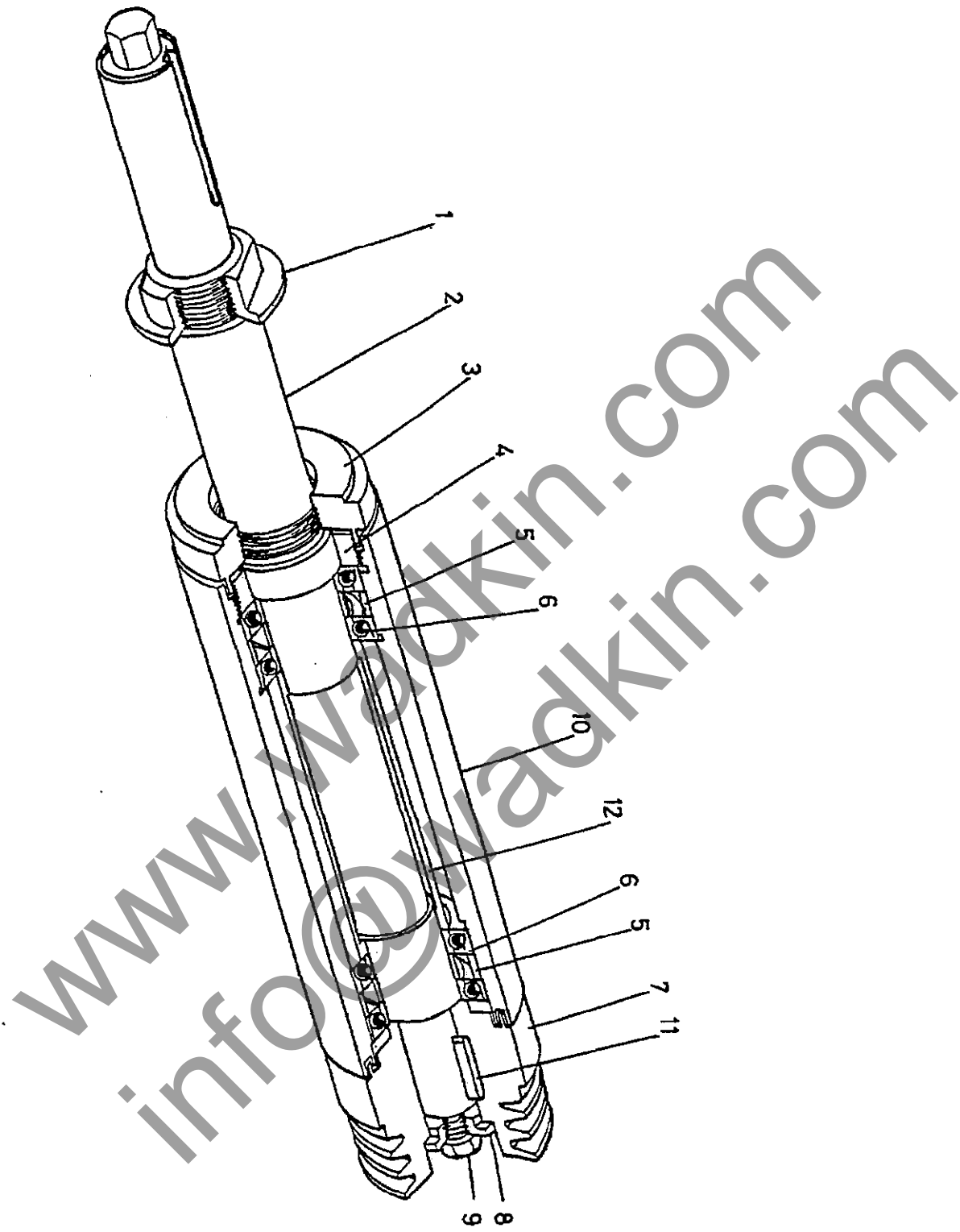

FIG 17 TOP HEAD SPINDLE UNIT



18. BOTTOM HEAD SPINDLE UNIT - 40MM DIAMETER SQUARE SHOULDER

| Ref. No. | Description | No. Off |
|----------|---|---------|
| 1 | Locking nut | 1 |
| 2 | 40mm square shoulder near side head spindle | 1 |
| 3 | Nut for spindle front bearing L.H | 1 |
| 4 | Nut for spindle barrel front bearing | 1 |
| 5 | Bearing spacer rings | 2 |
| *6 | R.H.P. Paired bearings 7009 TDUF EP7 | 2 |
| 7 | Spindle pulley (refer to motor and drive belt data) | 1 |
| 8 | Pulley spigot for spindle | 1 |
| 9 | hexagon head set screw M12 x 40mm | 1 |
| 10 | Barrel housing | 1 |
| 11 | Parallel key 12mm x 8mm x 50mm long | 1 |
| * | 'Kluber' grease packed | |

www.wadkin.com
info@wadkin.com

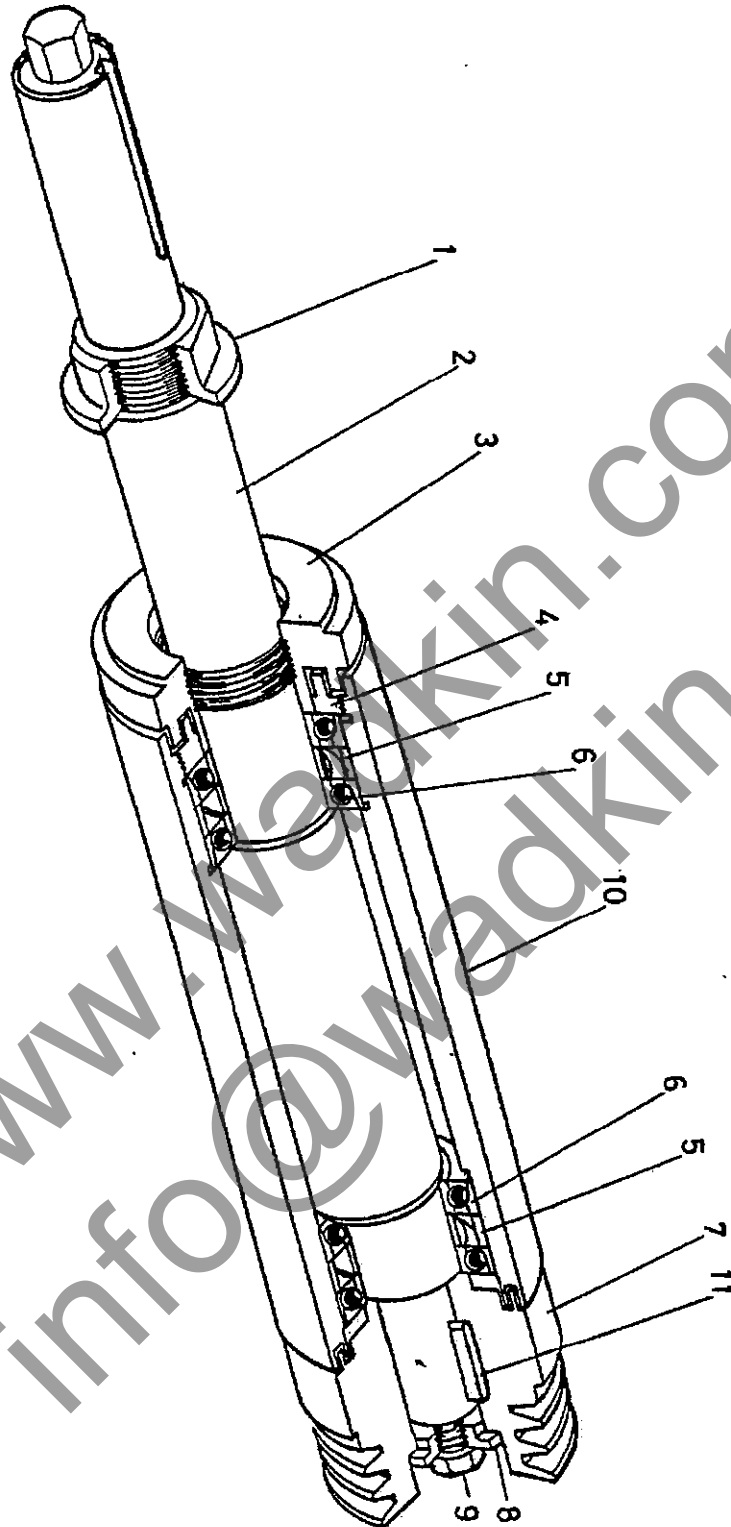

FIG 18 BOTTOM HEAD SPINDLE UNIT

**19. BOTTOM HEAD SPINDLE UNIT - 45mm, 50mm AND 1 13/16" DIAMETER SQUARE SHOULDER**

| Ref. No. | Description | No. Off |
|----------|--|-------------|
| 1 | Locking nut | 1 |
| 2 | 45mm diameter square shoulder spindle or 50mm diameter square shoulder spindle or 1 13/16 diameter square shoulder spindle | 1 1 1 |
| 3 | Nut for spindle front bearing R.H. | 1 |
| 4 | Nut for spindle barrel front bearing | 1 |
| 5 | Spacer rings for bearings | 2 |
| *6 | R.H.P. Paired bearings 7009 TDUF EP7 | 2 |
| 7 | Spindle pulley (refer to motor and drive belt data) | 2 |
| 8 | Pulley spigot for spindle | 1 |
| 9 | Hexagon head setscrew M12 x 40mm | 1 |
| 10 | Barrel housing | 1 |
| 11 | Parallel key 12mm x 8mm x 50mm long | 1 |
| 12 | Bearing spacer | 1 |
| * | 'Kluber' grease packed | |

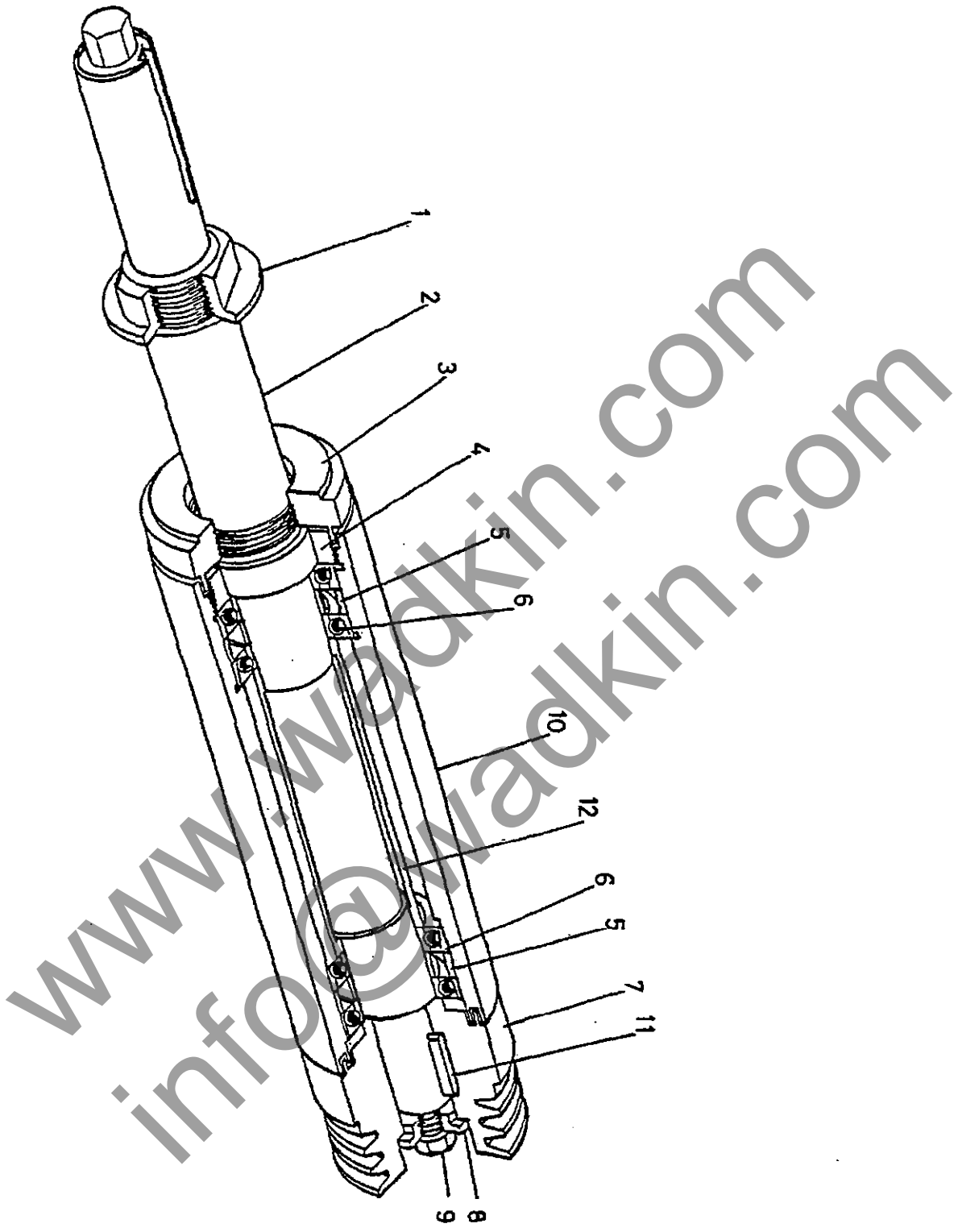

FIG 19 BOTTOM HEAD SPINDLE UNIT

20. NEAR SIDE HEAD CARRIAGE UNIT ADJUSTING MECHANISM

| Ref. No. | Description | No. Off |
|----------|---|---------|
| 1 | Carriage for near side head spindle | 1 |
| 2 | Bearing plate for near side head winding shafts | 1 |
| 3 | Nut for vertical side head adjustment | 1 |
| 4 | Vertical adjusting screw | 1 |
| 5 | Mitre gear bracket for side head adjustment | 1 |
| 6 | Front horizontal shaft vertical adjustment | 1 |
| 7 | Front horizontal shaft lateral adjustment | 1 |
| 8 | Locking shaft for spindle barrel | 1 |
| 9 | Straight mitre bevel gear | 2 |
| 10 | Clamping block for horizontal movement | 1 |
| 11 | Mitre gear through shaft, for rise and fall and vee belt drive | 1 |
| 12 | Calibrated dial for traverse screw | 2 |
| 13 | Guard for gear bracket | 1 |
| 14 | Nut for lateral movement | 1 |
| 15 | Collar for horizontal shaft | 1 |
| 16 | Hexagon socket grub screw M6 x 8mm long | 1 |
| 17 | Hexagon socket cap screw M8 x 25mm long | 2 |
| 18 | Front horizontal shaft lateral adjustment | 1 |
| 19 | GACO 'O' ring RMO 246 24 | 2 |
| 20 | Key 5mm x 5mm x 20mm | 5 |
| 21 | Hexagon socket cap screw M8 x 35mm long | 2 |
| 22 | Hexagon socket grub screw M6 x 6mm long | 2 |
| 23 | Loose collar Ø 20 | 2 |
| 24 | Taper pin | 2 |
| 25 | INA Thrust washer AS 2035 | 1 |
| 26 | Tension pin Ø 6 | 2 |
| 27 | Hexagon head setscrew M8 x 60mm long | 2 |
| 28 | Grease nipple NA5799 | 2 |
| 29 | Plain washer M8 | 2 |
| 30 | Hexagon head setscrew M10 x 80mm long | 1 |
| 31 | Plain washer M10 | 1 |
| 32 | Nut M10 | 1 |
| 33 | M12 Self locking nut | 1 |
| 34 | INA Thrust bearing AXK 2542 | 2 |
| 35 | INA Thrust washer AS 2542 | 2 |
| 36 | INA Thrust washer LS 2542 | 2 |
| 37 | Notch nut M24 x 1.5 | 2 |
| 38 | Hexagon head setscrew M10 x 20mm long | 1 |
| 39 | Large plain washer M10 | 1 |
| 40 | Stud M12 x 70mm long | 1 |
| 41 | Locking handle M12 x 25mm male | 2 |
| 42 | Brass pad | 1 |
| 43 | Tension pin Ø 4 | 1 |
| 44+ | Hexagon socket cap screw M10 x 45mm long (Bearing plate fastening to carriage slide) | 4 |
| 45 | Front horizontal shaft vertical adjustment | 1 |
| 46 | Square end shaft extension | 2 |
| 47 | Taper pin | 2 |
| 48 | 'SIKO' digital readout (0902E 4mm) | 2 |
| 49 | 'INA' shaft washer WS 81104 | 1 |
| 50 | 'INA' Thrust bearing AXK 2035 | 2 |
| 51 | 'INA' Thrust washer AS 2035 | 3 |

+ Not shown

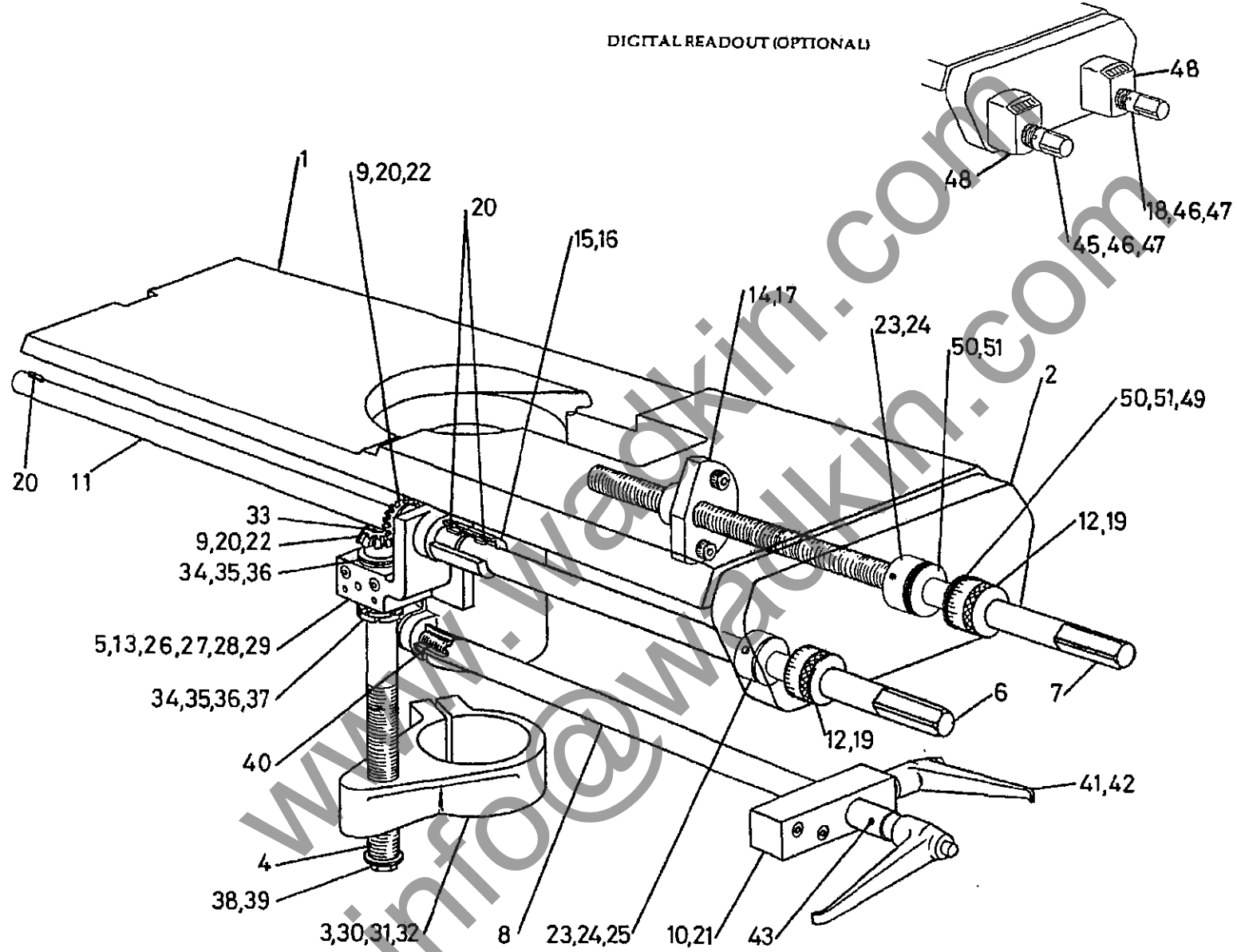

FIG 20 NEAR SIDE HEAD CARRIAGE UNIT ADJUSTING MECHANISM



21. TOP ROLLER PRESSURE UNIT

| Ref. No. | Description | No. Of |
|----------|-------------------------------------|--------|
| 1 | Barrel, top pressure roller | 1 |
| 2 | Spring tensioner, top pressure | 1 |
| 3 | Split clamp, top pressure barrel | 1 |
| 4 | Roller arm, top pressure | 1 |
| 5 | Roller, top pressure | 1 |
| 6 | Roller pin, top pressure | 1 |
| 7 | Spring, infeed pressure | 1 |
| 8 | Tension pin, 8mm dia. x 24mm long | 1 |
| 9 | Tension pin, 5mm dia. x 24mm long | 1 |
| 10 | Hexagon head screw, M12 x 45mm long | 2 |
| 11 | Circlip, 20mm external | 1 |
| 12 | Bearing, SKF 6004 2RS | 1 |

www.wadkin.com
info@wadkin.com

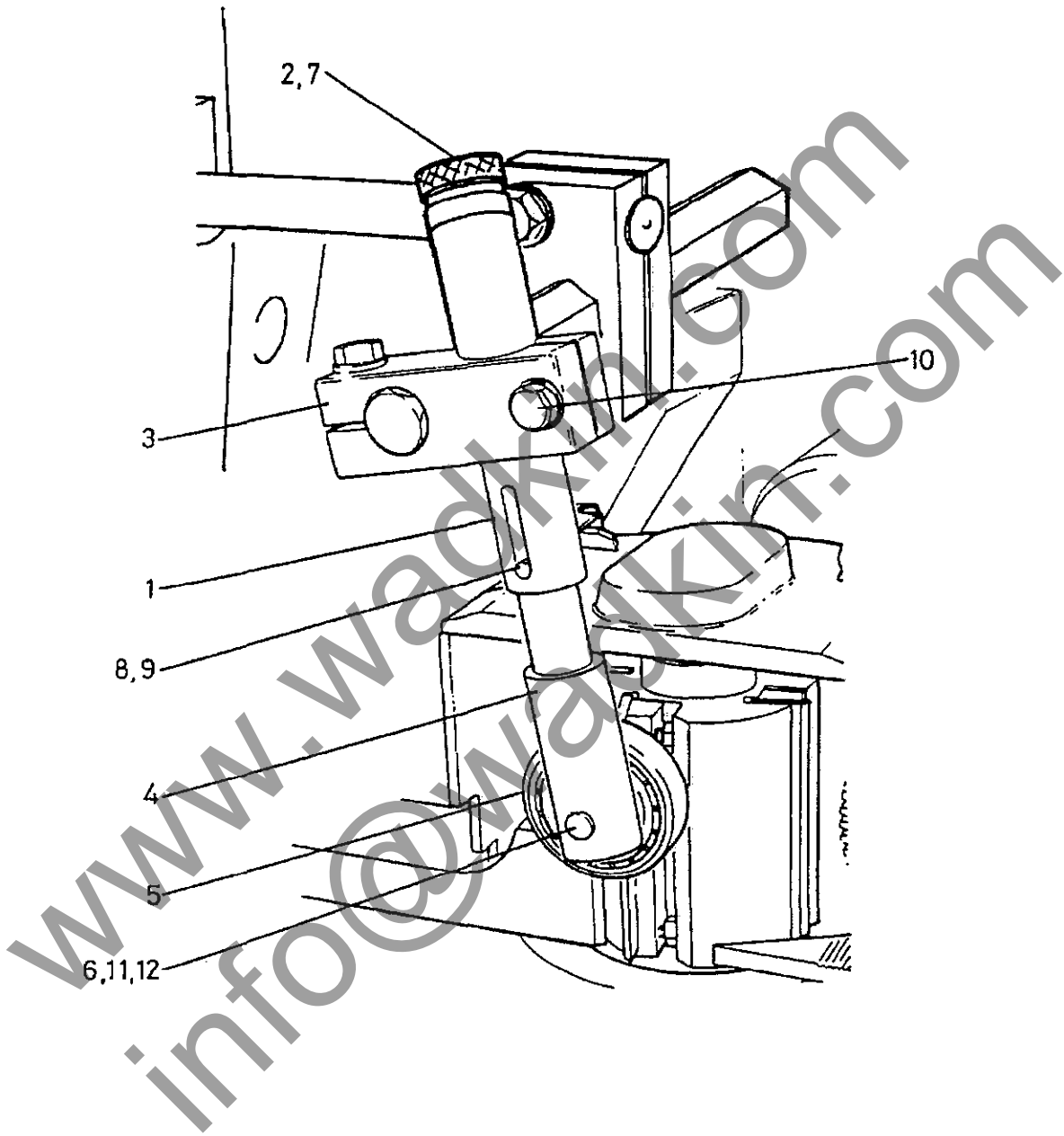

FIG 21 TOP ROLLER PRESSURE UNIT

22. SINGLE SIDE ROLLER PRESSURE UNIT OPPOSITE FENCE SIDE HEAD

| Ref. No. | Description | No. Off |
|----------|---|---------|
| 1 | Bracket, single roller side pressure unit | 1 |
| 2 | Pin, side pressure roller | 1 |
| 3 | Pressure roller | 1 |
| 4 | Sliding shaft, pressure roller | 1 |
| 5 | Infeed pressure spring | 1 |
| 6 | Hexagon head screw, M12 x 35mm long | 2 |
| 7 | Washer 12mm, bright mild steel | 2 |
| 8 | 'Heyco'nylon domed plug, black, 8mm hole, | 1 |
| 9 | Circlip, 20mm external | 1 |
| 10 | Bearing, SKF 6004 2RS | 1 |
| 11 | Tension pin, 8mm dia x 30mm long | 1 |
| 12 | Tension pin, 5mm dia x 30mm long | 1 |

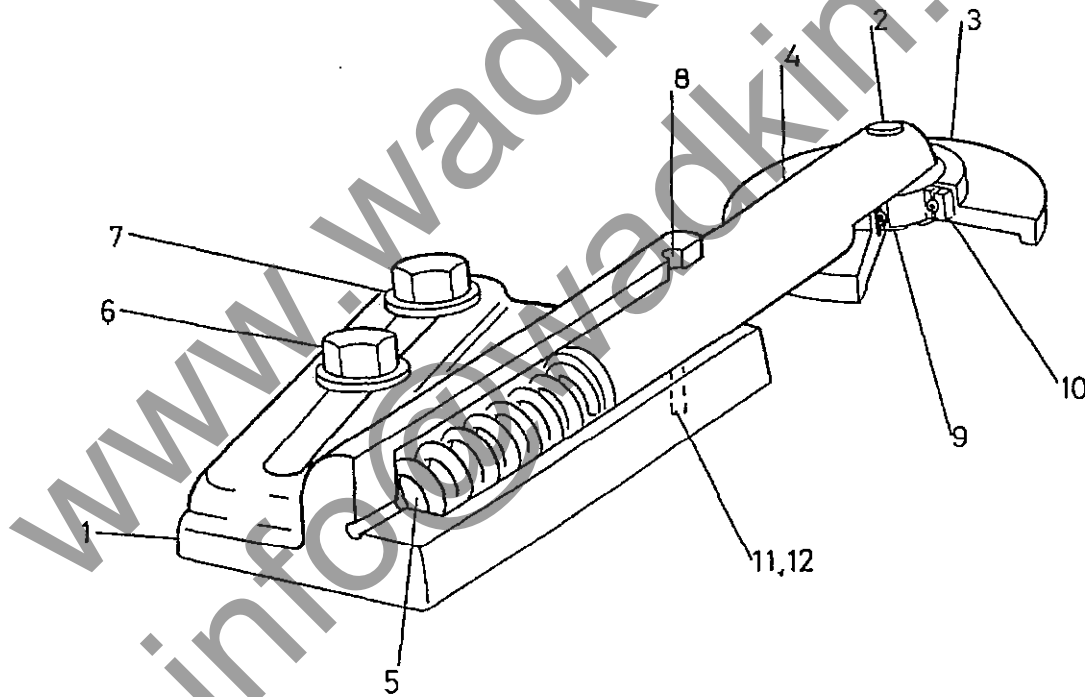

FIG 22 SINGLE SIDE ROLLER PRESSURE UNIT OPPOSITE FENCE SIDE HEAD

23. MOUNTING FOR TOP PAD OR ROLLER PRESSURE UNIT BEFORE TOP HEAD

| Ref. No. | Description | No. Off |
|----------|---|---------|
| 1 | Bracket, top pressure | 1 |
| 2 | Horizontal bar, longitudinal adjustment | 1 |
| 3 | Horizontal bar, transverse adjustment | 1 |
| 4 | Split clamp, top pressure horizontal bars | 1 |
| 5 | Screwed stud, M10 x 55mm long | 1 |
| 6 | Hexagon nut, M10 | 1 |
| 7 | Washer, 10mm, bright mild steel | 1 |
| 8 | Hexagon socket screw, M10 x 25mm long | 2 |
| 9 | Hexagon head screws, M12 x 40mm long | 2 |

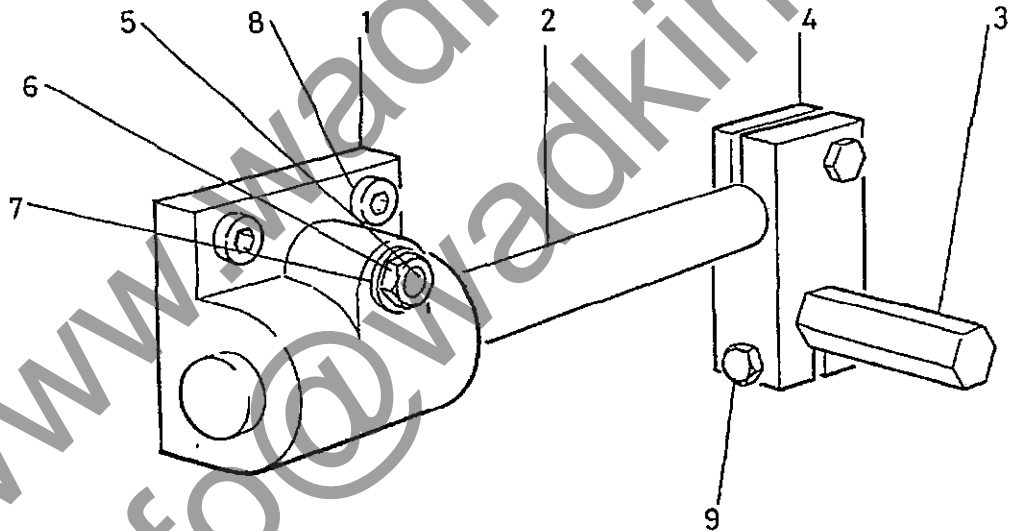

FIG 23 MOUNTING FOR TOP PAD OR ROLLER PRESSURE UNIT BEFORE TOP HEAD



24. UNIVERSAL HEAD ADJUSTING MECHANISM

| Ref. No. | Description | No. Off |
|----------|---|---------|
| 1 | Universal Head spindle, 40mm dia. sq.shoulder | 1 |
| 2 | Locking nut | 1 |
| 3 | Locking collar assembly | 1 |
| 4 | Vertical traverse screw | 1 |
| 5 | Digital readout | 1 |
| 6 | Vertical slide stand | 1 |
| 7 | Locking handle, M10 X 50mm, male | 1 |
| 8 | Saddle, Universal Head | 1 |
| 9 | Locking handle | 1 |
| 10 | Digital readout | 1 |
| 11 | Horizontal traverse screw | 1 |
| 12 | Cross slide, Universal Head | 1 |
| 13 | Worm gear shaft | 1 |
| 14 | Electric motor, frame D132 | 1 |
| 15 | Drive pulley | 1 |
| 16 | Drive belt, Fenner, SPZ 940 | 3 |
| 17 | Pulley/belt housing | 1 |
| 18 | Pully/belt housing cover | 1 |
| 19 | Spindle carriage, Universal head | 1 |
| 20 | Bolt, spindle carriage | 2 |
| 21 | Wormwheel, Universal Head | 1 |

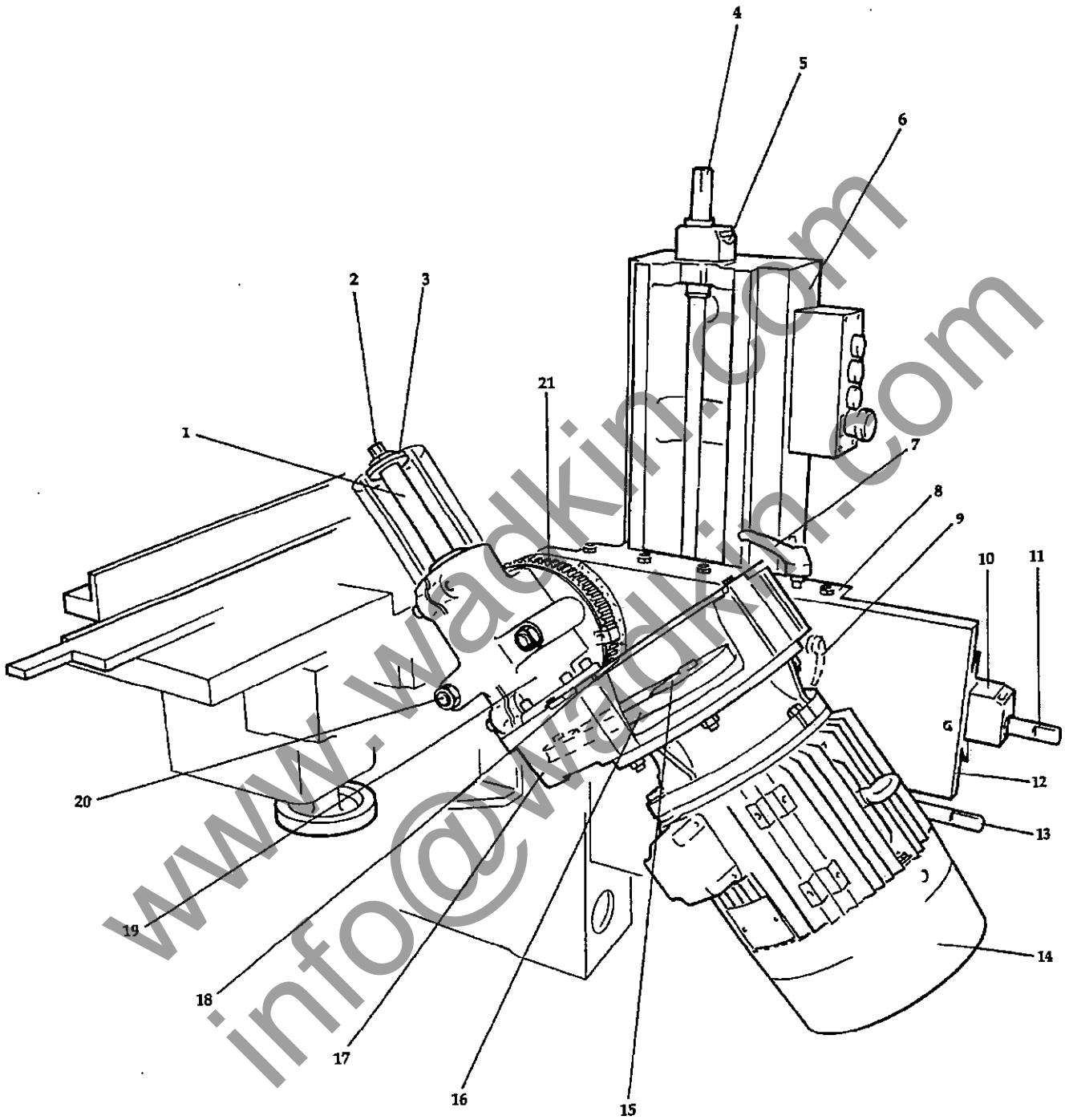

FIG 24 UNIVERSAL HEAD ADJUSTING MECHANISM

25. NEAR SIDE HEAD JOINTER MK II

| Ref. No. | Description | No. Off |
|----------|--|---------|
| 1 | Slide for near side head jointer | 1 |
| 2 | Intermediate slide for jointer | 1 |
| 3 | Saddle for near side head jointer | 1 |
| 4 | Wear strip | 1 |
| 5 | Traverse screw | 1 |
| 6 | Screw for jointer feed | 1 |
| 7 | Square drive adaptor | 1 |
| 8 | Wear strip for saddle | 1 |
| 9 | Sleeve for jointer feed | 1 |
| 10 | Nut for jointer feed | 1 |
| 11 | Clamp screw | 1 |
| 12 | Spring anchor pin | 2 |
| 13 | Spring anchor post | 1 |
| 14 | Dial for jointer adjustment | 1 |
| 15 | Block for jointer screw bearing | 1 |
| 16 | Holder for straight jointer stone | 1 |
| 17 | Clamp | 1 |
| 18 | Body for profile jointer stone | 1 |
| 19 | Washer | 1 |
| 20 | Plate | 1 |
| 21 | Extension spring | 2 |
| 22 | 'GACO' 'O' ring RMO 445-30 | 1 |
| 23 | Helicoil insert F112 - N24 M12 | 1 |
| 24 | Bronze headed bush 16mm O/D x 10mm I/D x 10mm long | 2 |
| 25 | Plain washer M10 | 2 |
| 26 | Hexagon socket capscrew M6 x 16mm long | 2 |
| 27 | Hexagon socket capscrew M6 x 12mm long | 3 |
| 28 | Tension pin \emptyset 4 x 12mm long | 2 |
| 29 | Hexagon head setscrew M6 x 12mm long | 2 |
| 30 | Tension pin \emptyset 6 x 40mm long | 2 |
| 31 | Hexagon socket capscrew M8 x 30mm long | 2 |
| 32 | Hexagon head setscrew M8 x 25mm long | 4 |
| 33 | Lock nut M12 | 1 |
| 34 | Handwheel | 1 |
| 35 | Handwheel | 1 |
| 36 | Taper pin | 1 |
| 37 | Hexagon socket grubscrew M6 x 25mm long | 2 |
| 38 | Lock nut M6 | 2 |
| 39 | Hexagon socket grubscrew M8 x 25mm long | 4 |
| 40 | Lock nut M8 | 4 |
| 41 | Stud M12 x 55mm long | 1 |
| 42 | Collar nut WDS 404-204 M12 | 1 |

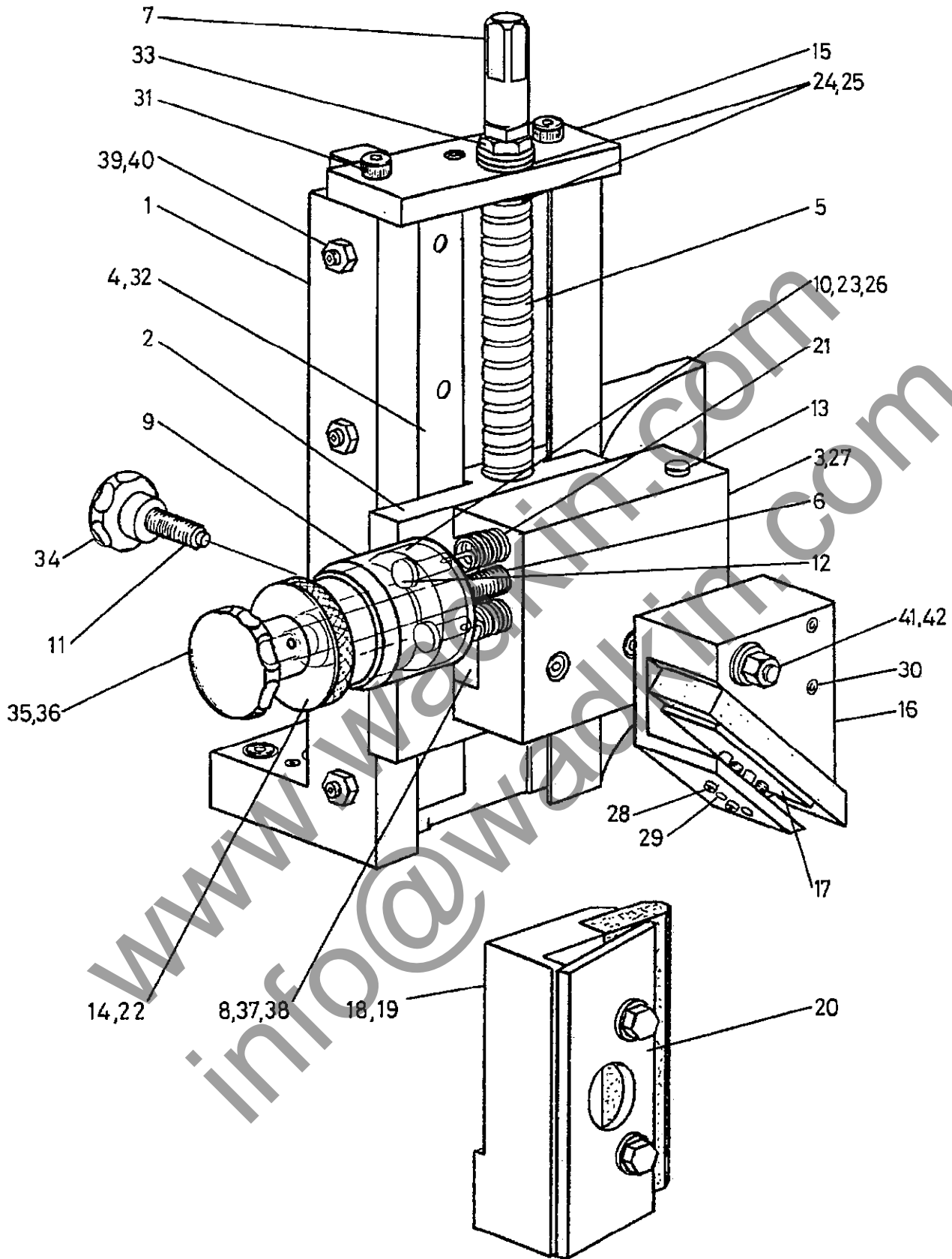

FIG 25 NEAR SIDE HEAD JOINTER

26. FENCE SIDE HEAD JOINTER MK 11

| Ref. No. | Description | No. Off |
|----------|---|---------|
| 1 | Slide for fence side head jointer feed | 1 |
| 2 | Spring anchor post | 1 |
| 3 | Post for Spring | 2 |
| 4 | Slideway for jointer | 1 |
| 5 | Foot for jointer slideway | 1 |
| 6 | Bevel gear | 2 |
| 7 | Screw for jointer rise and fall | 1 |
| 8 | Nut for jointer rise and fall | 1 |
| 9 | Shaft for bevel gear | 1 |
| 10 | Nut for jointer feed | 1 |
| 11 | Knob | 1 |
| 12 | Dial for jointer adjustment | 1 |
| 13 | Screw for jointer feed | 1 |
| 14 | Sleeve for jointer feed | 1 |
| 15 | Bracket for bevel gears | 1 |
| 16 | Wear strip for jointer | 1 |
| 17 | Slide for feed control | 1 |
| 18 | Vertical wear strip | 1 |
| 19 | Vertical slideway | 1 |
| 20 | Vertical slide | 1 |
| 21 | Holder for straight jointer stone | 1 |
| 22 | Body for profile jointer stone | 1 |
| 23 | Washer | 1 |
| 24 | Plate | 1 |
| 25 | Clamp | 1 |
| 26 | Tension pin $\varnothing 4 \times 12$ mm long | 2 |
| 27 | Hexagon head setscrew M6 x 12 mm long | 2 |
| 28 | Tension pin $\varnothing 6 \times 40$ mm long | 2 |
| 29 | Plain dowel $\varnothing 10 \times 25$ mm long | 1 |
| 30 | Hexagon socket capscrew M6 x 20mm long | 3 |
| 31 | Hexagon socket grubscrew M6 x 12mm long | 9 |
| 32 | Hexagon socket capscrew M8 x 60mm long | 2 |
| 33 | Headed bronze bush 22 mm O/D x 12mm long | 4 |
| 34 | Loose collar 28 mm O/D x 16 mm I/D x 12mm thick | 1 |
| 35 | INA Thrust washer As 1730 | 2 |
| 36 | Hexagon locknut M16 | 2 |
| 37 | Plain washer | 1 |
| 38 | Hexagon socket grubscrew M6 x 6mm long | 2 |
| 39 | Key 5 mm x 5 mm x 20 mm long | 2 |
| 40 | Extension spring | 2 |
| 41 | GACO 'O' ring seal RMO 445-30 | 2 |
| 42 | Hexagon socket capscrew M6 x 16mm long | 1 |
| 43 | M12 Helicoil insert | 8 |
| 44 | Hexagon socket capscrew M6 x 65mm long | 1 |
| 45 | Hexagon socket capscrew M8 x 45mm long (foot to slide) | 1 |
| 46 | Tension pin $\varnothing 6 \times 50$ mm long | 2 |
| 47 | No 1 Taper pin | 1 |
| 48 | M10 Plain washer | 1 |

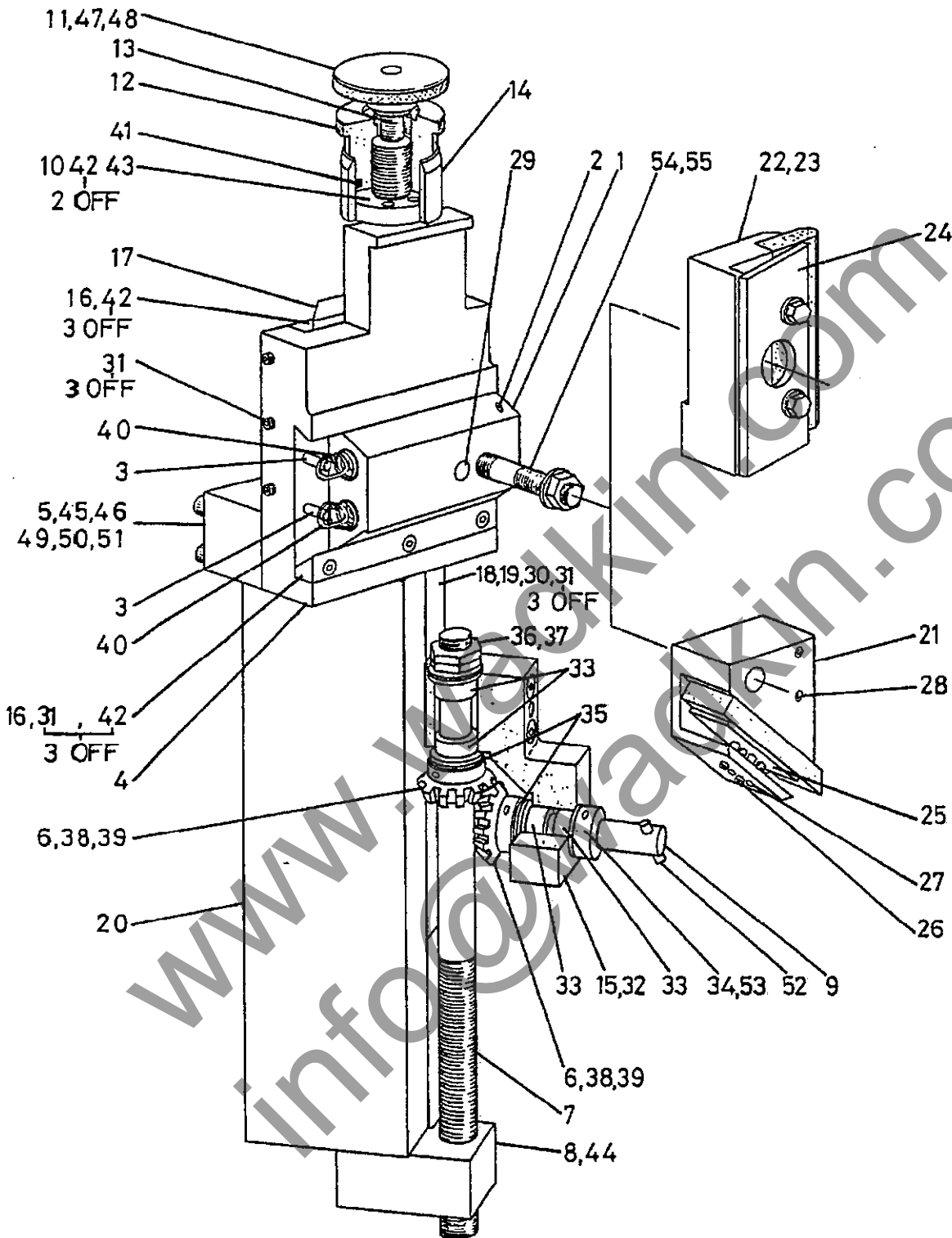

FIG 26 FENCE SIDE HEAD JOINTER

26. FENCE SIDE HEAD JOINTER MK 11 (cont.)

| Ref. No. | Description | No. Off |
|----------|---|---------|
| 49 | Hexagon socket capscrew M6 x 60mm long | 4 |
| 50 | Spring washer M6 | 4 |
| 51 | Tension pin 0 6 x 32mm long (foot to slideway) | 2 |
| 52 | Tension pin 0 6 x 32 mm long | 1 |
| 53 | Taper pin No 2 | 1 |
| 54 | Stud M12 x 55 mm long | 1 |
| 55 | | 1 |

www.wadkin.com
info@wadkin.com

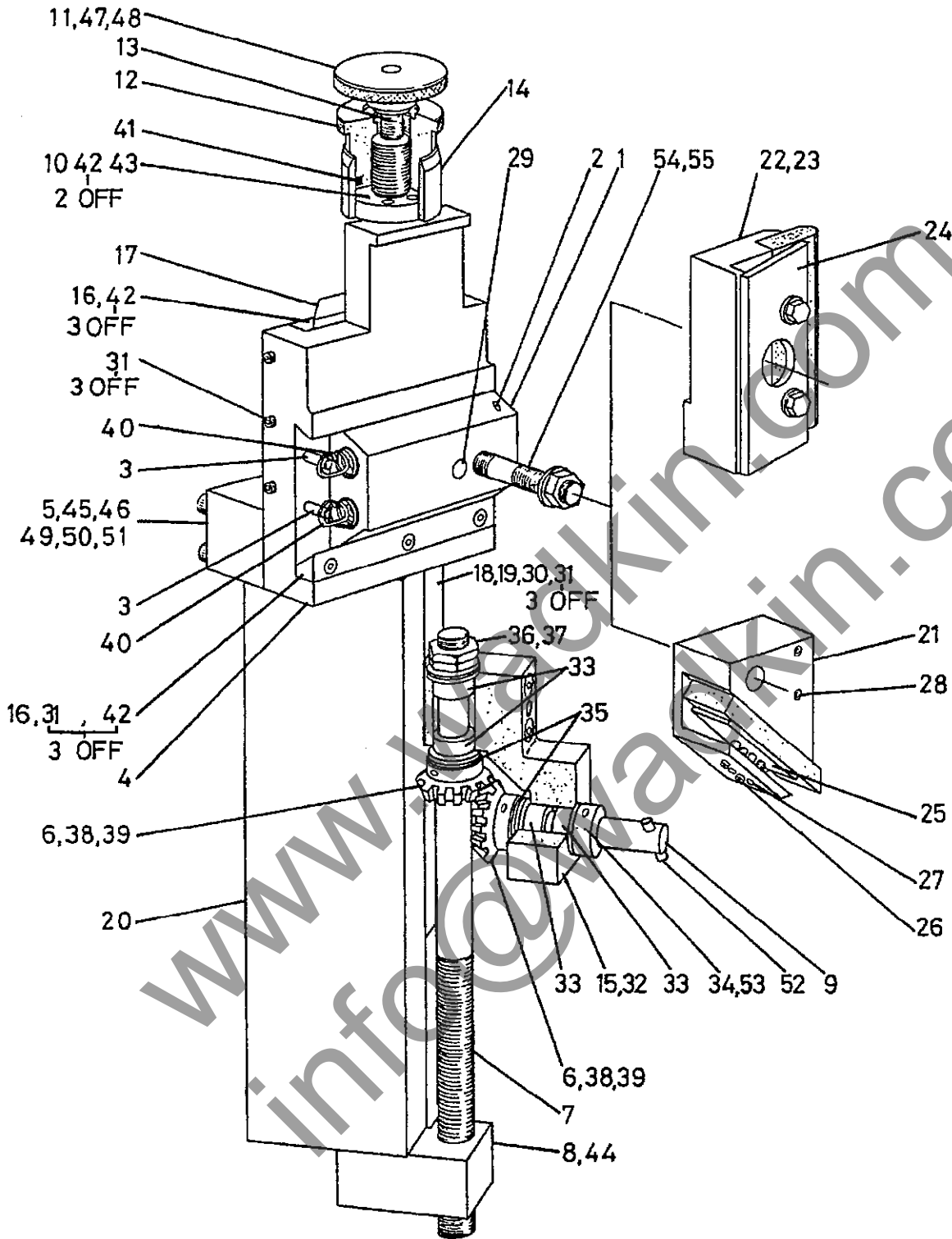

FIG 26 FENCE SIDE HEAD JOINTER



27. TOP HEAD JOINTER

Build of the top head Jointer is the same as the MK II Near side head Jointer with the exceptions of the below items:-

| Ref. No. | Description | No. Off |
|----------|----------------------------|---------|
| 1 | Slide for top head Jointer | 1 |
| 2 | Wear Strip | 1 |
| 3 | Traverse Screw | 1 |

www.wadkin.com
info@wadkin.com

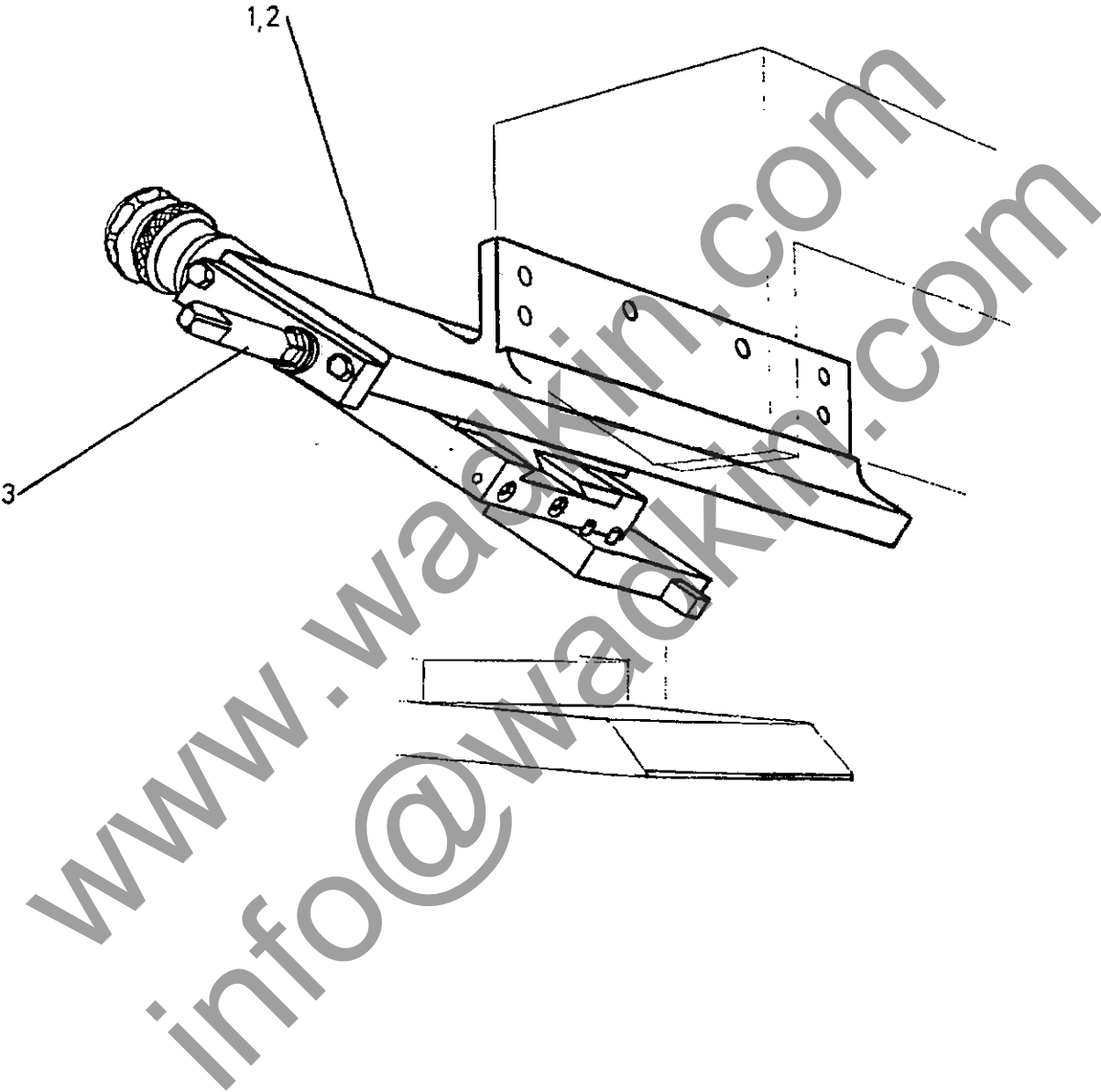

FIG 27 TOP HEAD JOINTER

28. SECOND BOTTOM HEAD JOINTER

| Ref. No. | Description | No. Off |
|----------|---|---------|
| 1 | Slideway for bottom head jointer feed | 1 |
| 2 | Slide for bottom head jointer feed | 1 |
| 3 | Saddle for bottom head jointer | 1 |
| 4 | Slide for bottom head jointer traverse | 1 |
| 5 | Screw for horizontal jointer traverse | 1 |
| 6 | Nut for jointer feed | 1 |
| 7 | Sleeve for jointer feed | 1 |
| 8 | Screw for jointer feed | 1 |
| 9 | Dial for jointer adjustment | 1 |
| 10 | Jointer feed slide strip | 1 |
| 11 | Spring anchor pin | 2 |
| 12 | Block for jointer traverse/stop | 2 |
| 13 | Square drive adaptor | 1 |
| 14 | Wear Strip | 1 |
| 15 | Clamp Block | 1 |
| 16 | Body for profile jointer stone | 1 |
| 17 | Plate for profile jointer stone holder | 1 |
| 18 | Washer for profile jointer stone holder body | 1 |
| 19 | Holder for straight jointer stone | 1 |
| 20 | Clamp plate | 1 |
| 21 | Tension pin 6mm dia x 40mm long | 2 |
| 22 | Tension pin 4mm dia x 12mm long | 2 |
| 23 | Hexagon socket grubscREW M6 x 12mm long | 2 |
| 24 | Handwheel | 1 |
| 25 | Taper Pin | 1 |
| 26 | Large diameter plain washer M10 | 1 |
| 27 | Helicoil insert M12 F112-N24 | 1 |
| 28 | Hexagon socket capscrew M6 x 16mm long | 2 |
| 29 | 'GACO' 'O' ring RMO 445-30 | 1 |
| 30 | Extension spring | 2 |
| 31 | Tension pin 4mm dia x 16mm long | 2 |
| 32 | Hexagon socket grubscREW M8 x 25mm long | 3 |
| 33 | Hexagon locknut M8 | 3 |
| 34 | Hexagon head setscrew M8 x 30mm long | 2 |
| 35 | Plain washer M8 | 2 |
| 36 | Hexagon socket capscrew M6 x 25mm long | 4 |
| 37 | Bronze headed bush 18mm O/D x 12mm I/D x 8mm long | 2 |
| 38 | Plain collar 25mm O/D x 12mm I/D x 12mm width | 1 |
| 39 | Tension pin 4mm dia x 24mm long | 1 |
| 40 | Plain washer M12 | 1 |
| 41 | Hexagon locknut M12 | 1 |
| 42 | Stud M12 x 55mm long | 1 |
| 43 | Hexagon socket capscrew M8 x 50mm long | 2 |
| 44 | Hexagon socket capscrew M8 x 25mm long | 3 |
| 45 | Hexagon socket capscrew M8 x 40mm long | 1 |
| 46 | Hexagon locknut M8 | 1 |
| 47 | Collar nut 'WDS' 404-204 M12 | 1 |
| 48 | Plain washer M12 | 1 |
| 49 | Hexagon nut M12 | 1 |
| 50 | Hexagon socket capscrew M10 x 20mm long | 2 |



OPERATING INSTRUCTIONS

SECTION

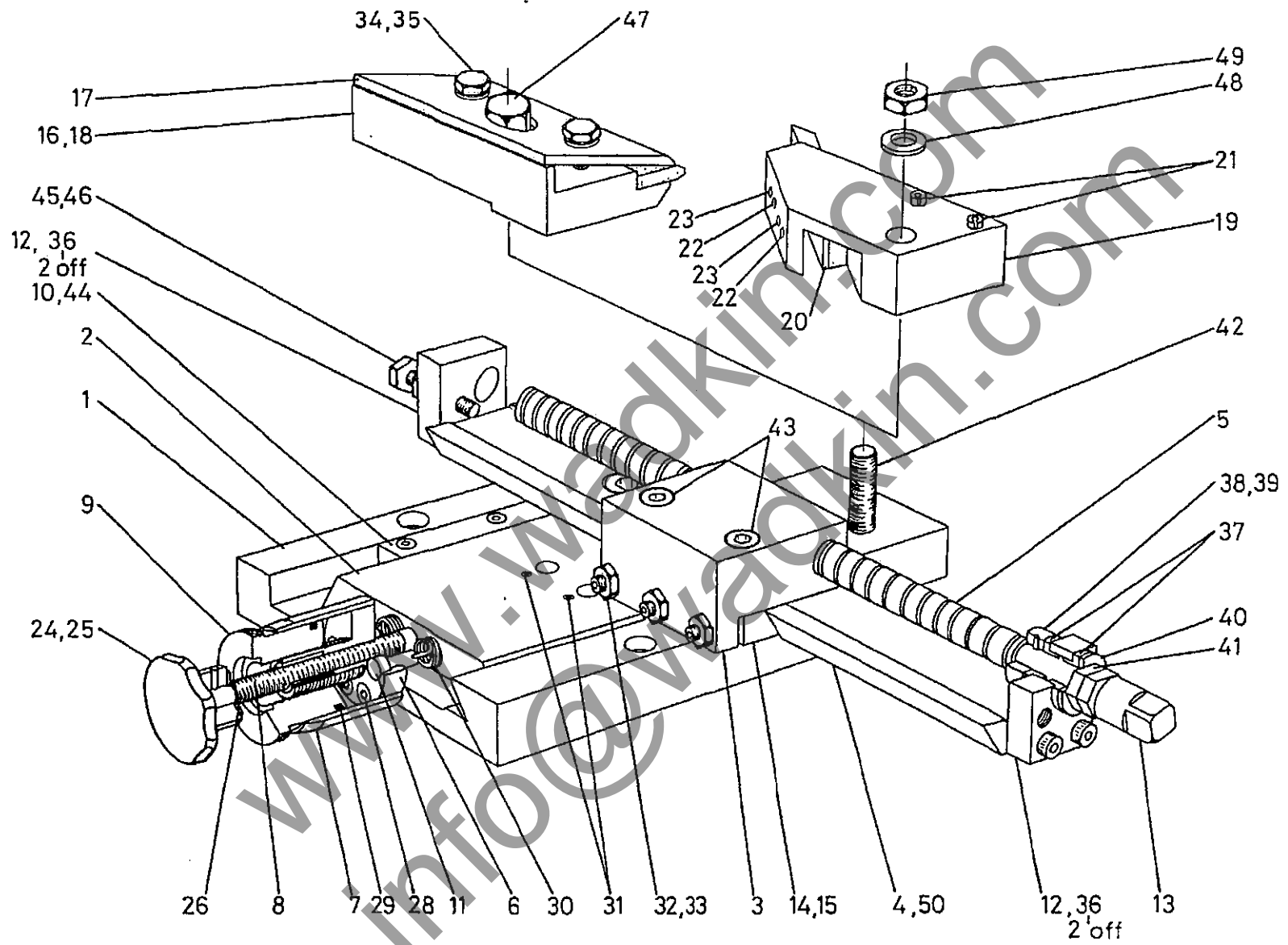

FIG 28 SECOND BOTTOM HEAD JOINTER

29. BOTTOM HEAD - RISE AND FALL

| Ref No. | Description | No. off |
|---------|---|---------|
| 1 | Bevel box for bottom head adjustment | 1 |
| 2 | Bracket for cross shaft bearing | 1 |
| 3 | Cross shaft for bottom head rise and fall | 1 |
| 4 | Square end shaft extension | 1 |
| 5 | End cap for rise and fall bevel box | 1 |
| 6 | Screw for bottom head rise and fall | 1 |
| 7 | Bevel gear for rise and fall | 1 |
| 8 | Bevel gear for rise and fall | 1 |
| 9 | Cover for bevel box | 1 |
| 10 | Sealing ring | 1 |
| 11 | Key 8mm x 7mm x 20mm | 1 |
| 12 | 'INA' Shaft washer WS 81105 | 2 |
| 13 | 'INA' Thrust washer AS 2542 | 2 |
| 14 | 'INA' Thrust bearing AXK 2542 | 2 |
| 15 | Plain washer M16 | 1 |
| 16 | Hexagon lock nut M16 | 2 |
| 17 | Taper pin | 1 |
| 18 | Siko position unicator 09011 2mm | 1 |
| 19 | Key 5mm x 5mm x 20mm | 1 |
| 20 | Collar dia 20mm bore | 1 |
| 21 | Hexagon socket grubscrew M6 x 6mm long | 1 |
| 22 | 'INA' Thrust washer AS 2035 | 4 |
| 23 | 'INA' Thrust bearing AXK 2035 | 2 |
| 24 | External circlip dia. 16mm | 1 |
| 25 | Pan head screw M4 x 10mm long | 3 |
| 26 | Hexagon socket capscrew M6 x 20mm long | 3 |
| 27 | Bush 25mm O/D x 20mm I/D x 25mm long | 1 |
| 28 | Bush 30mm O/D x 25mm I/D x 25mm long | 1 |
| 29 | Bush 25mm O/D x 20mm I/D x 15mm long | 2 |
| 30 | Hexagon socket capscrew M6 x 75mm long | 4 |

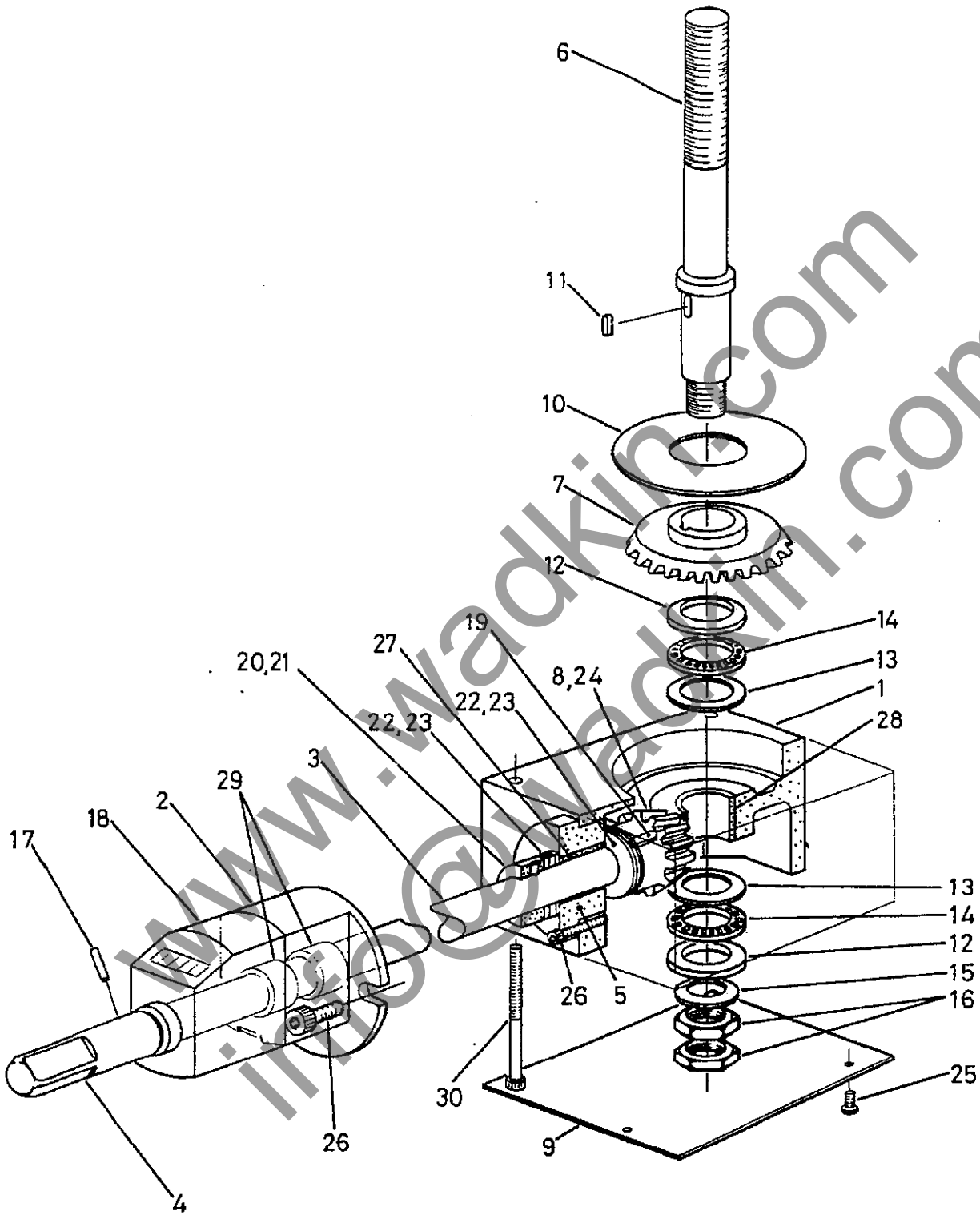

FIG 29. BOTTOM HEAD - RISE AND FALL

30 BOTTOM HEADS AXIAL ADJUSTMENT

| Ref. No. | Description | No. Off |
|----------|--|---------|
| 1 | Nut for Horizontal Head Adjustment | 1 |
| 2 | Shaft for Horizontal Head Adjustment | 1 |
| 3 | M24 x 1.5 Chamfered Notch Nut | 2 |
| 4 | Bearing Bracket for Horizontal Head Adjustment | 1 |
| 5 | 'INA' Thrust Bearing AXK 2542 | 2 |
| 6 | 'INA' Thrust Washer AS 2542 | 4 |
| 7 | Sprocket for Horizontal Head Axial Adjustment | 2 |
| 8 | 'RENOLD' Roller Chain No. 111046 12.9mm (1/2") Pitch, 40 Pitches | 1 |
| 9 | No.4 Taper Pin | 1 |
| 10 | Shaft | 1 |
| 11 | 20mm I/D x 25mm O/D x 20mm long Bronze Bush | 2 |
| 12 | Square Shaft Extension | 1 |
| 13 | Chain Link Connector | 1 |
| 14 | Taper Pin No.1 | 1 |
| 15 | Bearing Block | 1 |
| 16 | Digital Readout | 1 |
| 17 | Threaded Collar M20 Trapezoidal | 1 |
| 18 | Hexagon Socket Grubscrew M8 x 8mm long | 2 |
| 19 | 6mm dia x 40mm long Tension Pin | 1 |

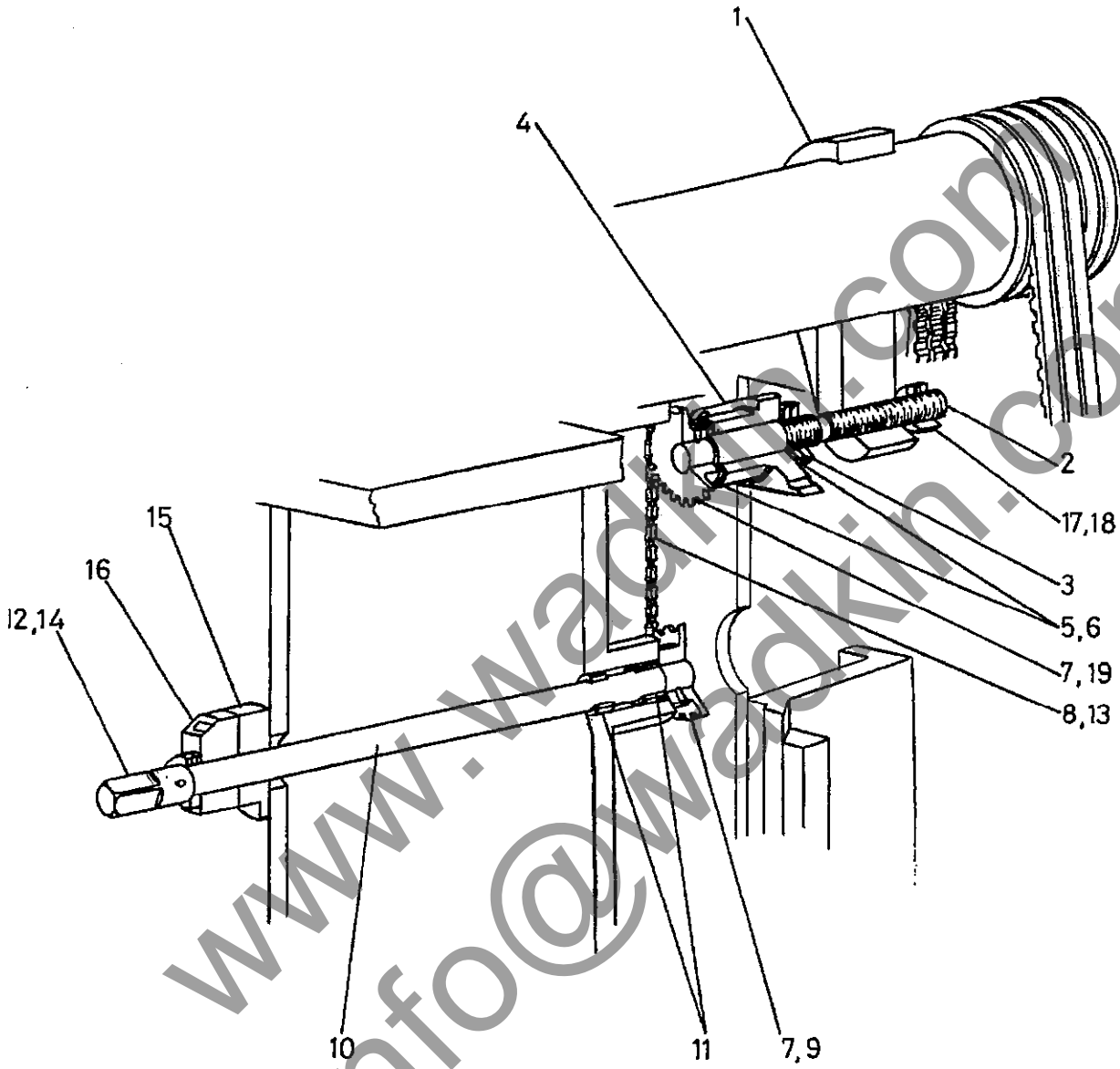
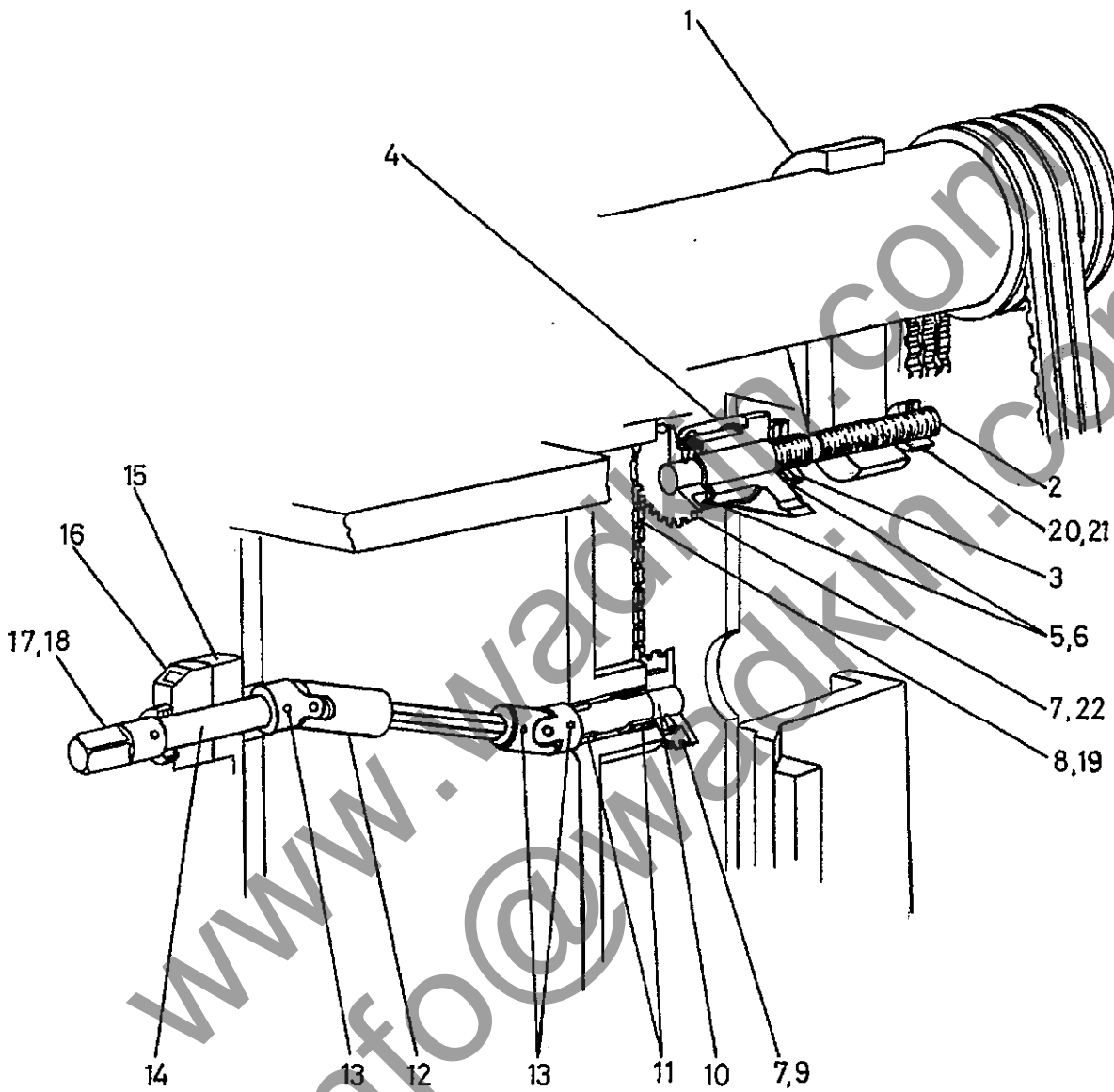

FIG 30 BOTTOM HEADS AXIAL ADJUSTMENT

31 TOP HEADS AXIAL ADJUSTMENT

| Ref. No. | Description | No. Off |
|----------|---|---------|
| 1 | Nut for Horizontal Head Adjustment | 1 |
| 2 | Shaft for Horizontal Head Adjustment | 1 |
| 3 | M24 x 1.5 Chamfered Notch Nut | 2 |
| 4 | Bearing Bracket for Horizontal Head Adjustment | 1 |
| 5 | 'INA' Thrust Bearing AXK 2542 | 2 |
| 6 | 'INA' Thrust Washer AS 2542 | 4 |
| 7 | Sprocket for Horizontal Head Axial Adjustment | 2 |
| 8 | 'RENOLD' Roller Chain No. 111046 12.9mm ($\frac{1}{2}$ ") Pitch, 40 Pitches | 1 |
| 9 | No.4 Taper Pin | 1 |
| 10 | Shaft | 1 |
| 11 | 20mm I/D x 25mm O/D x 20mm long Bronze Bush | 2 |
| 12 | Universal Coupling with 12mm A/F Telescopic Shaft | 1 |
| 13 | 6mm dia. x 24mm long Tension Pin | 1 |
| 14 | Shaft for Horizontal Head Cross Adjustment | 1 |
| 15 | Bearing Block | 1 |
| 16 | Digital Readout | 1 |
| 17 | Square Shaft Extension | 1 |
| 18 | Taper Pin No.1 | 1 |
| 19 | Chain Connector Link | 1 |
| 20 | Threaded Collar M20 Trapezoidal | 1 |
| 21 | Hexagon Socket Grubscrew M8 x 8mm long | 2 |
| 22 | 6mm dia. x 40mm long Tension Pin | 1 |

**FIG 31 TOP HEADS AXIAL ADJUSTMENT**

32. DOUBLE THRO FEED GEARBOX

| Ref. No. | Description | No. Off |
|----------|--|---------|
| 1 | Worm shaft | 1 |
| 2 | Bearing end cap | 2 |
| 3 | End cap for feed roll drive shaft | 2 |
| 4 | Bush for feed roll drive shaft | 2 |
| 5 | Feed roll drive shaft | 2 |
| 6 | Bearing spacer | 3 |
| 7 | Gear | 1 |
| 8 | Shaft for worm wheel drive | 1 |
| 9 | Intermediate gear | 1 |
| 10 | Worm wheel | 1 |
| 11 | End cap | 1 |
| 12 | Locknut | 1 |
| 13 | Bearing housing | 1 |
| 14 | Bearing end cap | 1 |
| 15 | Gearbox for double feed rolls | 1 |
| 16 | Plug $\frac{1}{2}$ B.S.P taper | 2 |
| 17 | Plug $\frac{1}{2}$ B.S.P | 1 |
| 18 | Hexagon socket capscrew M6 x 25mm long | 16 |
| 19 | Key 8mm x 7mm x 20mm | 2 |
| 20 | Bearing SKF 6206 ball bearing | 2 |
| 21 | Thrust bearing SKF 51106 | 2 |
| 22 | Bronze bush 20mm I/D x 25mm O/D x 25mm long | 2 |
| 23 | Gaco spiroseal | 2 |
| 24 | Key 8mm x 7mm x 60mm | 1 |
| 25 | Key 8mm x 7mm x 32mm | 2 |
| 26 | Gaco oil seal WR 826 | 2 |
| 27 | Bearing SKF 7206 angular contact | 4 |
| 28 | Tolerance ring | 1 |
| 29 | Hexagon socket capscrew M4 x 20mm long | 4 |
| 30 | Hexagon socket capscrew M4 x 12mm long | 4 |
| 31 | Hexagon socket capscrew M6 x 16mm long | 6 |
| 32 | Hexagon socket countersunk screw M4 x 8mm long | 1 |

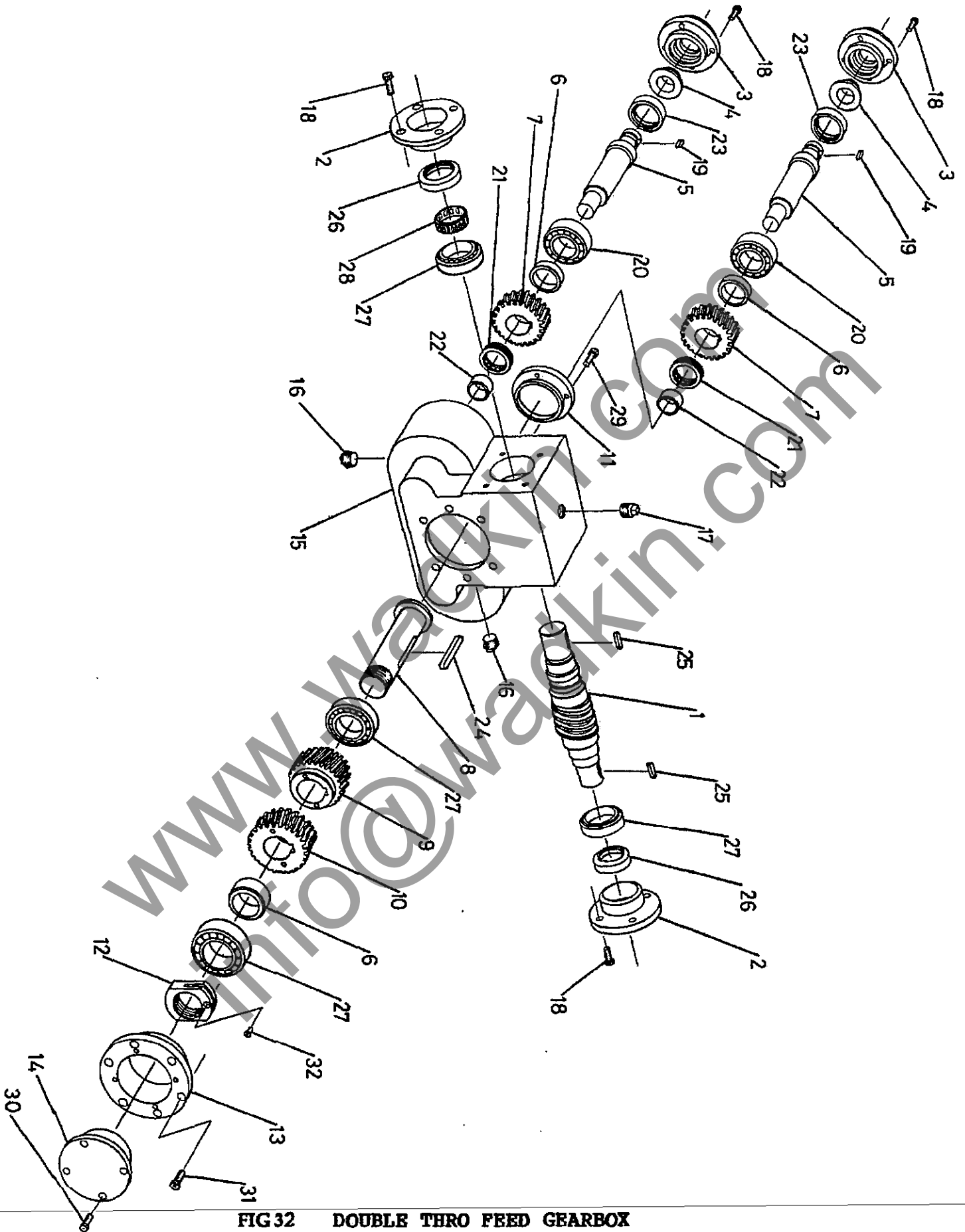

FIG32 DOUBLE THRO FEED GEARBOX

33. SINGLE THRO FEED GEARBOX

| Ref. No. | Description | No. Off |
|----------|--|---------|
| 1 | Worm shaft | 1 |
| 2 | Bearing end cap | 2 |
| 3 | End cap for feed roll drive shaft | 1 |
| 4 | Bush for feed roll drive shaft | 1 |
| 5 | Feed roll drive shaft | 1 |
| 6 | Bearing spacer | 2 |
| 7 | Gear | 1 |
| 8 | Shaft for worm wheel drive | 1 |
| 9 | Intermediate gear | 1 |
| 10 | Worm wheel | 1 |
| 11 | End cap | 1 |
| 12 | Locknut | 1 |
| 13 | Bearing housing | 1 |
| 14 | Bearing end cap | 1 |
| 15 | Gearbox for single feed roll | 1 |
| 16 | Plug $\frac{1}{4}$ B.S.P taper | 2 |
| 17 | Plug $\frac{1}{4}$ B.S.P | 1 |
| 18 | Hexagon socket capscrew M6 x 25mm long | 12 |
| 19 | Key 8mm x 7mm x 20mm | 1 |
| 20 | Bearing SKF 6206 ball bearing | 1 |
| 21 | Thrust bearing SKF 51106 | 1 |
| 22 | Bronze bush 20mm I/D x 25mm O/D x25mm long | 1 |
| 23 | Gaco spiroseal | 1 |
| 24 | Key 8mm x 7mm x 60mm | 1 |
| 25 | Key 8mm x 7mm x 32mm | 2 |
| 26 | Gaco oil seal WR 826 | 2 |
| 27 | Bearing SKF 7206 angular contact | 4 |
| 28 | Tolerance ring | 1 |
| 29 | Hexagon socket capscrew M4 x 20mm long | 4 |
| 30 | Hexagon socket capscrew M4 x 12mm long | 4 |
| 31 | Hexagon socket capscrew M6 x 16mm long | 6 |
| 32 | Hexagon socket countersunk screw M4 x 8mm long | 1 |

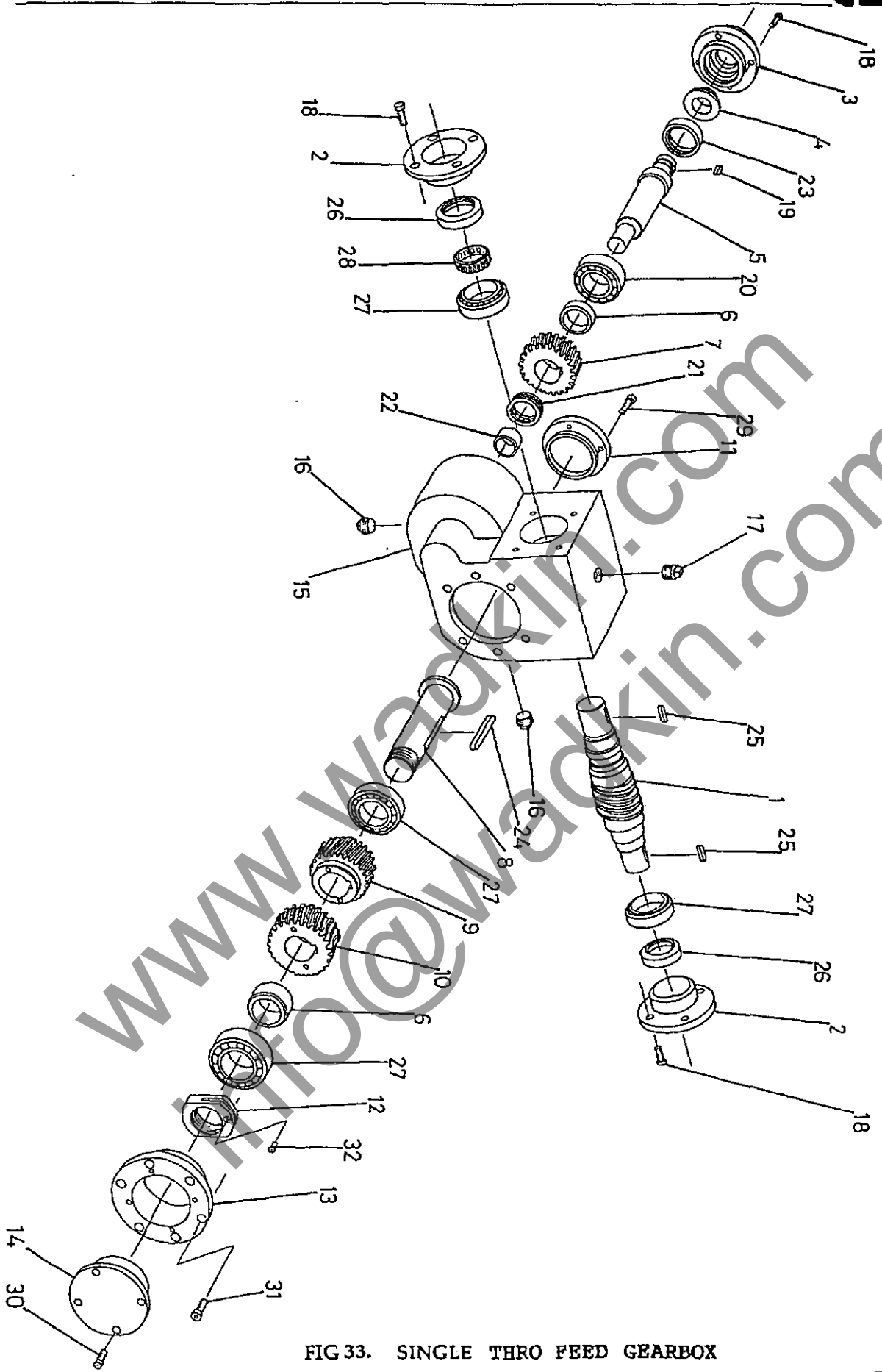

FIG 33. SINGLE THRO FEED GEARBOX

34. SINGLE THRO FEED GEARBOX USED WITH BOTTOM ROLL DRIVE

| Ref. No. | Description | No. Off |
|----------|--|---------|
| 1 | Worm shaft | 1 |
| 2 | Bearing end cap | 2 |
| 3 | End cap for feed roll drive shaft | 1 |
| 4 | Bush for feed roll drive shaft | 1 |
| 5 | Feed roll drive shaft | 1 |
| 6 | Bearing spacer | 2 |
| 7 | Gear | 1 |
| 8 | Shaft for worm wheel drive | 1 |
| 9 | Intermediate gear | 1 |
| 10 | Worm wheel | 1 |
| 11 | End cap | 1 |
| 12 | Locknut | 1 |
| 13 | Bearing housing | 1 |
| 14 | Bearing end cap | 1 |
| 15 | Gearbox for single feed roll | 1 |
| 16 | Plug $\frac{1}{4}$ B.S.P taper | 2 |
| 17 | Plug $\frac{1}{4}$ B.S.P | 1 |
| 18 | Hexagon socket capscrew M6 x 25mm long | 12 |
| 19 | Key 8mm x 7mm x 20mm | 1 |
| 20 | Bearing SKF 6206 ball bearing | 1 |
| 21 | Thrust bearing SKF 51106 | 1 |
| 22 | Bronze bush 20mm I/D x 25mm O/D x 25mm long | 1 |
| 23 | Gaco spiroseal | 1 |
| 24 | Key 8mm x 7mm x 60mm | 1 |
| 25 | Key 8mm x 7mm x 32mm | 2 |
| 26 | Gaco oil seal WR 826 | 2 |
| 27 | Bearing SKF 7206 angular contact | 4 |
| 28 | Tolerance ring | 1 |
| 29 | Hexagon socket capscrew M4 x 20mm long | 4 |
| 30 | Hexagon socket capscrew M4 x 12mm long | 4 |
| 31 | Hexagon socket capscrew M6 x 16mm long | 6 |
| 32 | Hexagon socket countersunk screw M4 x 8mm long | 1 |
| 3 | Key 6mm x 6mm x 30mm | 1 |

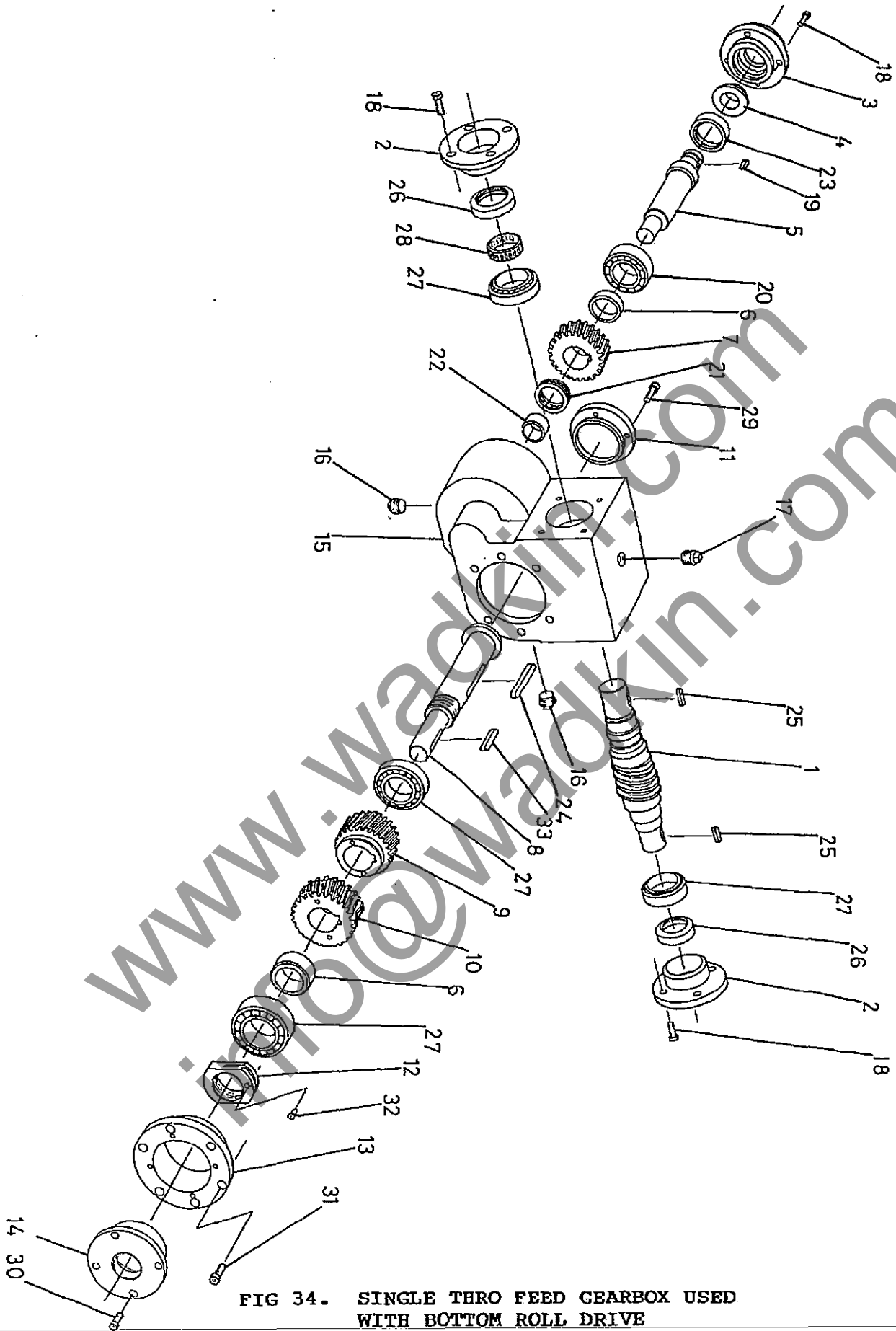

FIG 34. SINGLE THRO FEED GEARBOX USED WITH BOTTOM ROLL DRIVE



35 BOTTOM FEEDROLL DRIVE TRANSFER

| Ref. No. | Description | No. Off |
|----------|---|---------|
| 1 | Support plate | 1 |
| 2 | Cover for chain drive | 1 |
| 3 | Bearing housing | 1 |
| 4 | Driving shaft for bottom infeed roll | 1 |
| 5 | Top sprocket | 1 |
| 6 | Bottom sprocket | 1 |
| 7 | Support pillar for cover | 2 |
| 8 | Hexagon head setscrew M8 x 16mm long | 2 |
| 9 | Plain washer M8 | 5 |
| 10 | Chain 5/8" pitch x 57 pitches | 1 |
| 11 | Connecting Link No.26 | 1 |
| 12 | Hexagon socket grubscREW M8 x 25mm long | 1 |
| 13 | Hexagon socket grubscREW M6 x 25mm long | 1 |
| 14 | External Circlip 30mm dia | 4 |
| 15 | Internal Circlip 62mm dia | 2 |
| 16 | Bearing 6206-2RS 'SKF' | 2 |
| 17 | Key 8mm x 7mm x 32mm long | 1 |
| 18 | Key 8mm x 7mm x 36mm long | 1 |
| 19 | Hexagon head setscrew M8 x 25mm long | 3 |

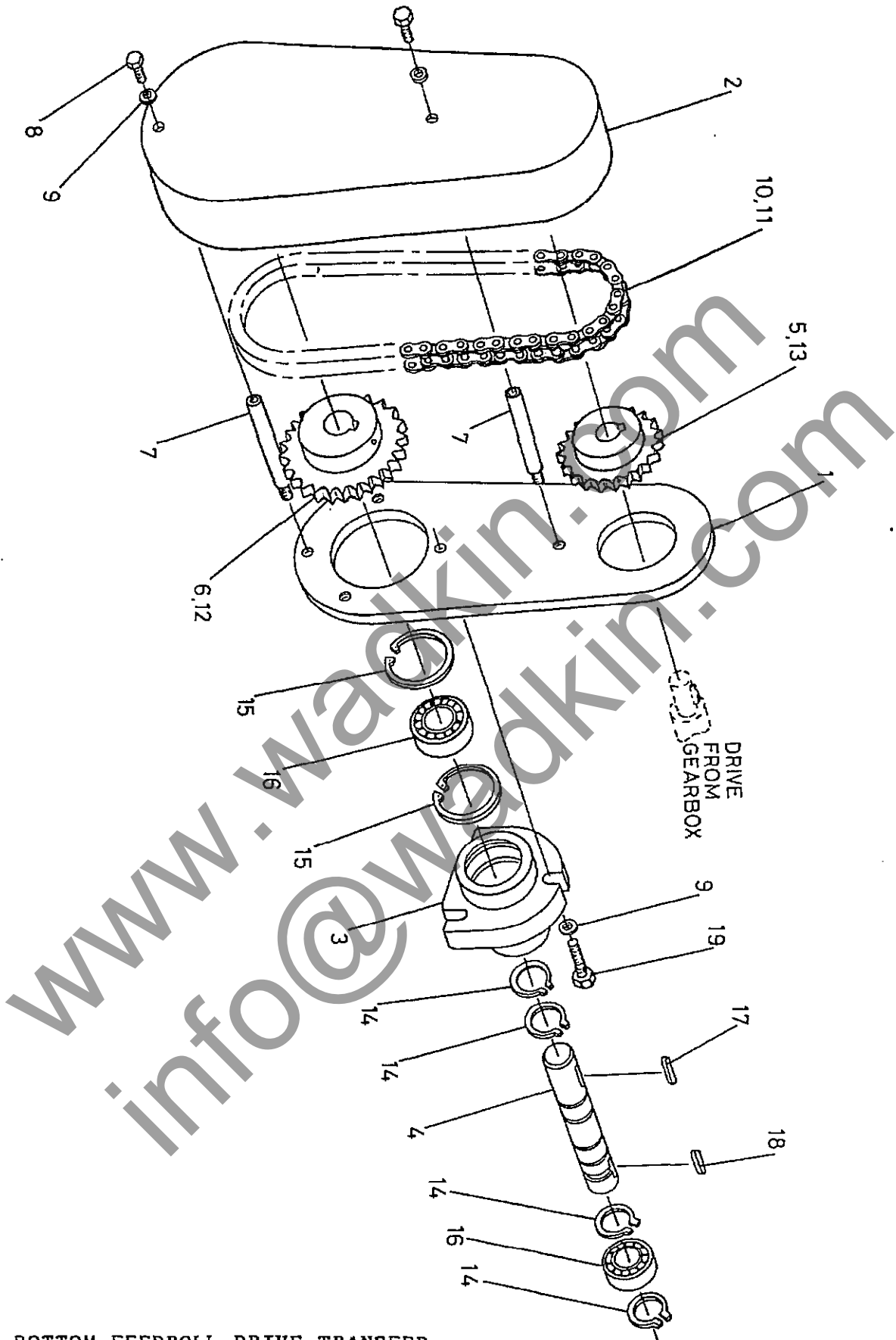

FIG 35 BOTTOM FEEDROLL DRIVE TRANSFER

36. SHAFT DRIVES

| Ref. No. | Description | No. Off |
|----------|---|---------|
| 1 | Gearbox | 1 |
| 2 | Coupling Segment dia.25 bore | 1 |
| 3 | Coupling Segment 19mm A/F hex bore | 1 |
| 4 | Drive Shaft (Specify length when ordering) | 1 |
| 5 | 'MINEX' gear ring | 1 |
| 6 | Grubscrew M6 x 8 mm long | 1 |
| 7 | Telescopic drive shaft for bottom feed roll | 1 |
| 8 | Telescopic drive shaft for top through feed rolls | 1 |
| 9 | P.V.C. gaiter for bottom feed roll | 1 |
| 10 | P.V.C. gaiter for top through feed rolls | 1 |
| 11 | Grubscrew M8 x 12mm long | 1 |
| 12 | Jubilee clip No.3X (80mm) | 1 |

Note: The illustration is only representational and parts should be related to the customers own machine configuration.

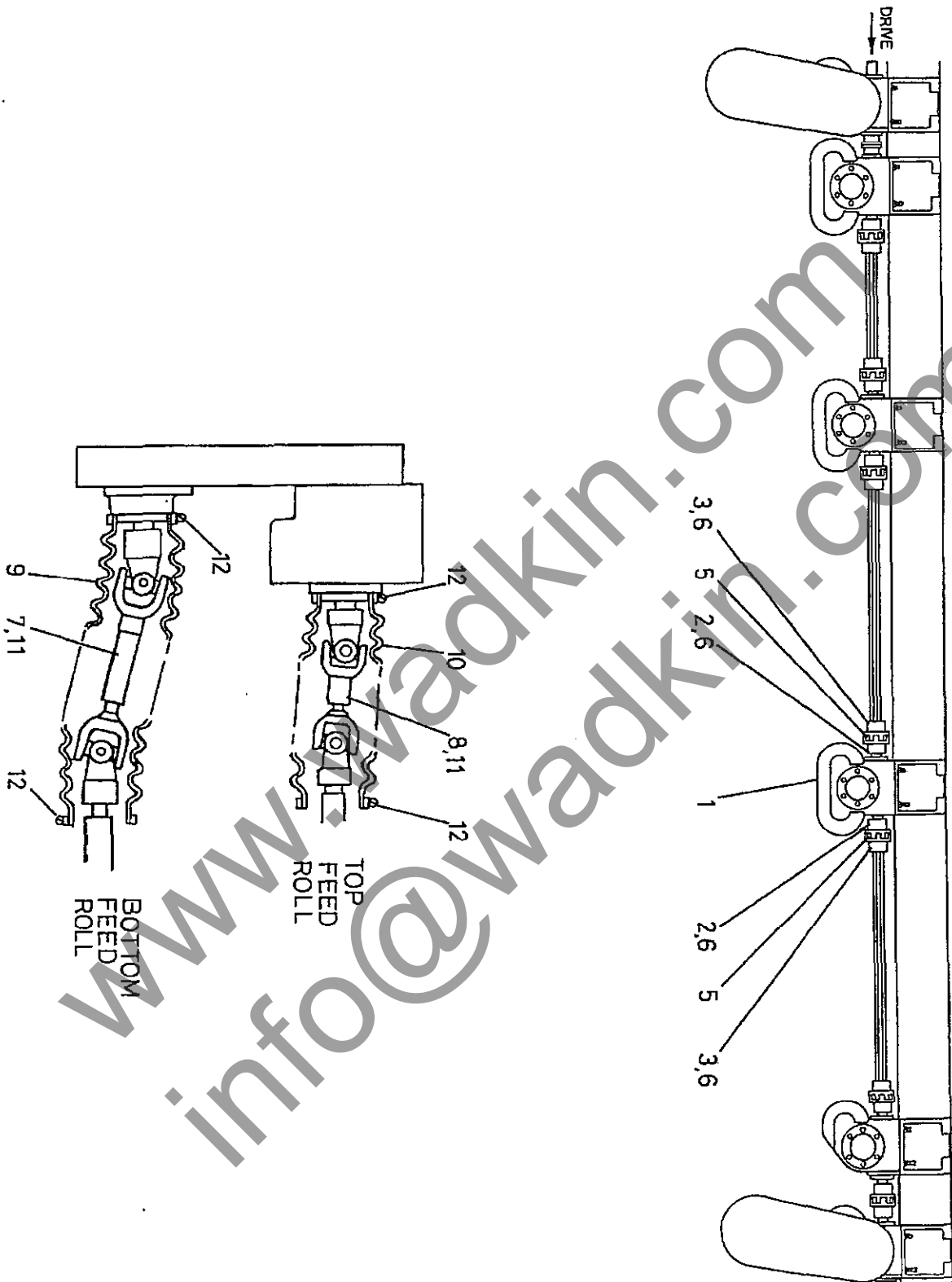

FIG 36 SHAFT DRIVES

37. NEAR SIDE HEAD CHIPBREAKER MK III

| Ref No. | Description | No. off |
|---------|--|---------|
| 1 | Plate for mounting near side head chipbreaker | 1 |
| 2 | Pad for near side head side guide | 1 |
| 3 | Block for mounting near side head chipbreaker | 1 |
| 4 | Arm for near side head chipbreaker | 1 |
| 5 | Hood for near side head | 1 |
| 6 | Latch for near side head chipbreakers | 1 |
| 7 | Block for retaining near side head chipbreaker | 1 |
| 8 | Spring | 1 |
| 9 | Block for near side head adjustment | 1 |
| 10 | Clamp for near side head adjustment | 1 |
| 11 | Bolt for near side head chipbreaker pivot | 1 |
| 12 | Nut for near side head chipbreaker spring | 1 |
| 13 | Plunger | 1 |
| 14 | Guide for spring | 1 |
| 15 | Screw for side guide adjustment | 1 |
| 16 | Stud for pivot bolt | 1 |
| 17 | Stud for block | 1 |
| 18 | Shoe for chipbreaker | 1 |
| 19 | Nut M12 | 6 |
| 20 | Plain washer M12 | 11 |
| 21 | Stud M12 x 55mm long | 3 |
| 22 | 'TNA' Thrust washer LS-3552 | 1 |
| 23 | 'TNA' Thrust bearing AXW - 30 | 2 |
| 24 | 'TNA' Needle bearing HK 3020 | 1 |
| 25 | 'TNA' Inner ring IR25 x 30 x 30 | 1 |
| 26 | (INA) Thrust washer AS-3047 | 1 |
| 27 | Notch nut | 1 |
| 28 | Tension pin dia 8mm x 40mm long | 1 |
| 29 | Hexagon socket cap screw M10 x 35mm long | 1 |
| 30 | 'helicoil' insert M12 | 1 |
| 31 | Taper pin No. 1 | 1 |
| 32 | Handwheel | 1 |
| 33 | Hexagon head setscrew M12 x 35mm long | 1 |
| 34 | Locknut M12 | 1 |
| 35 | Oilite bush | 2 |
| 36 | Locking handle | 3 |
| 37 | Stud m12 x 65mm long | 2 |
| 38 | Hexagon socket capscrew M12 x 30mm long | 2 |
| 39 | Stud M12 x 45mm long | 2 |
| 40 | Self locking nut M12 | 1 |

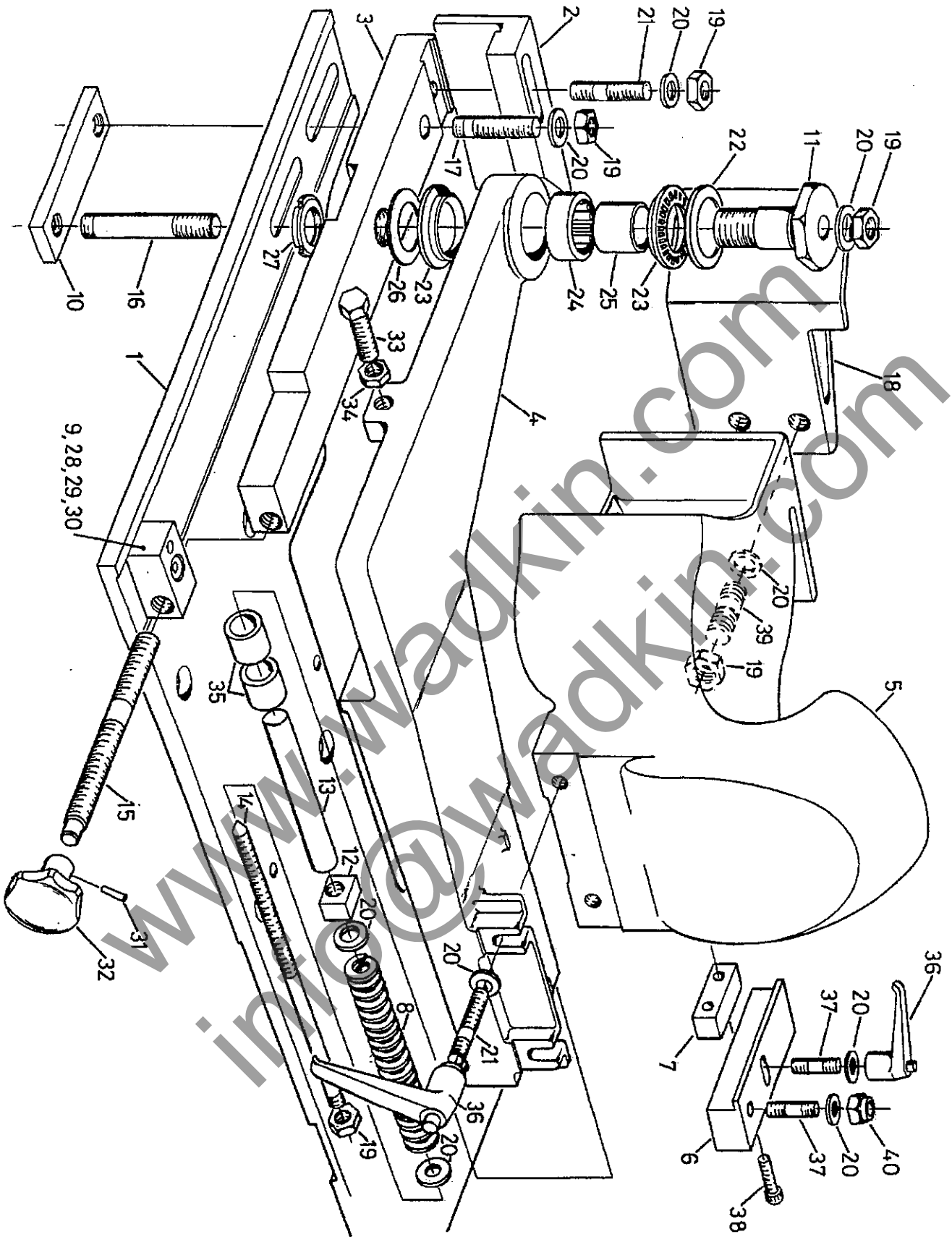

FIG 37. NEAR SIDE HEAD CHIPBREAKER MK III



LIST OF ILLUSTRATIONS

38 SECOND BOTTOM HEAD AXIAL ADJUSTMENT

| Ref No. | Description | No. Off |
|---------|--|---------|
| 1 | Bottom head Vertical Slide | 1 |
| 2 | Stretcher for bottom head | 1 |
| 3 | Front plate | 1 |
| 4 | Axial adjustment shaft | 1 |
| 5 | Clamping washer | 2 |
| 6 | Bearing bracket | 1 |
| 7 | Chain sprocket | 2 |
| 8 | Nut for bottom head rise and fall | 1 |
| 9 | Locking pad for slide | 1 |
| 10 | Shaft for bottom head clamping | 1 |
| 11 | Sprocket shaft for axial adjustment | 1 |
| 12 | Barrel clamping nut for axial adjustment | 1 |
| 13 | Square end shaft extension | 1 |
| 14 | Bracket for axial shaft bearings | 1 |
| 15 | No 1 Taper pin | 1 |
| 16 | Hexagon socket cap screw M8 x 25mm long | 2 |
| 17 | Plain washer M8 | 2 |
| 18 | Bush 25mm O/D x 20mm I/D x 15mm long | 2 |
| 19 | Hexagon socket capscrew M10 x 25mm long | 4 |
| 20 | Dowel 8mm diameter x 40mm long | 2 |
| 21 | Tension pin 8mm diameter x 35mm long | 2 |
| 22 | Bush 25mm O/D x 20mm I/D x 20mm long | 2 |
| 23 | Taper pin No 4 | 2 |
| 24 | 'INA' Thrust bearing AXK - 2542 | 2 |
| 25 | 'INA' Thrust washer AS 2542 | 4 |
| 26 | Notch nut M24 X 1.5mm pitch | 2 |
| 27 | Chain connecting link No 26 | 1 |
| 28 | 'Reynold' chain 1/2" pitch x39 pitches | 1 |
| 29 | Threaded collar M20 trapezoidal | 1 |
| 30 | Hexagon socket grub screw M8 X8mm long | 1 |
| 31 | 'Siko' position indicator 0902E 4mm | 1 |
| 32 | Locking handle M12 | 2 |
| 33 | Hexagon socket capscrew M10 X 30mm long (stretcher to side fastening) | 4 |

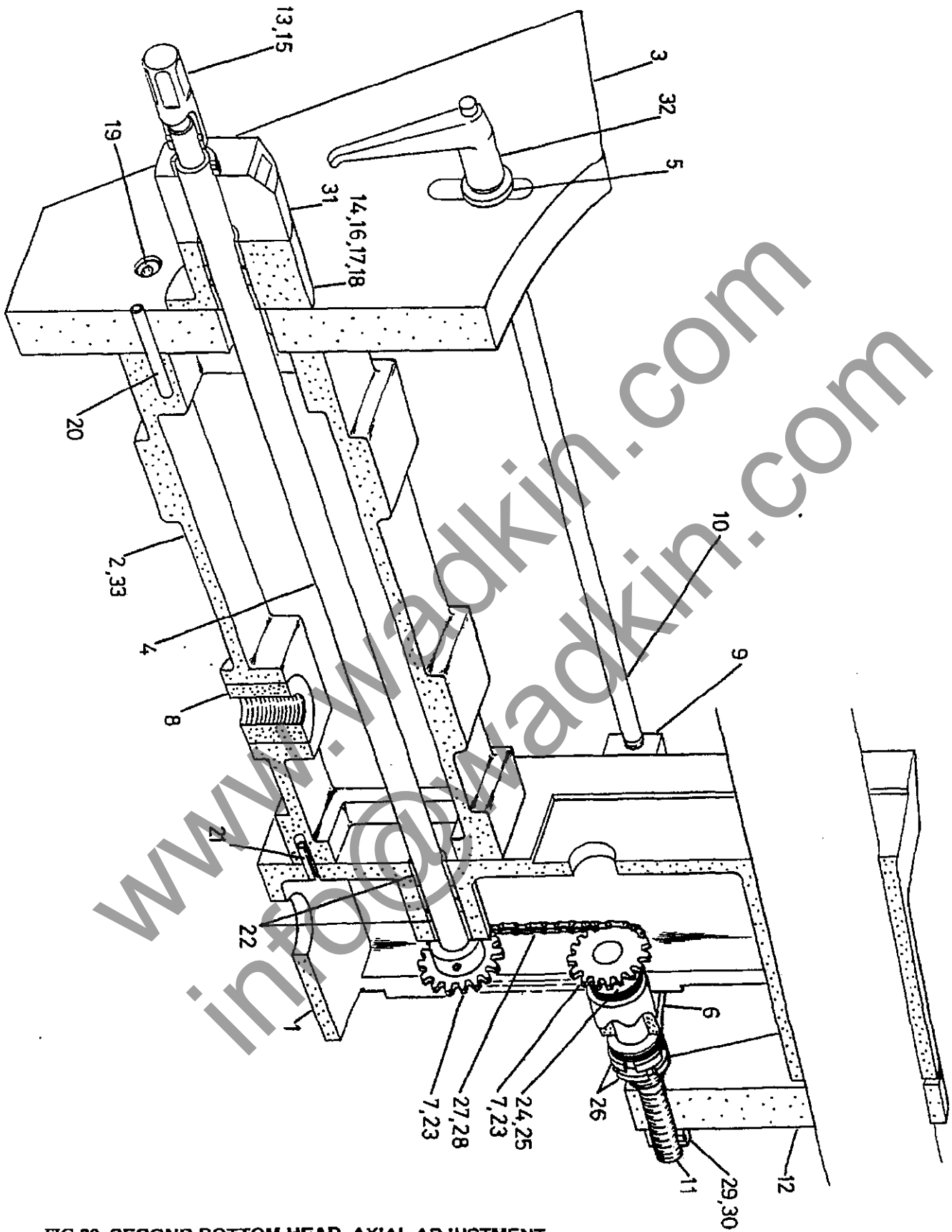

FIG 38 SECOND BOTTOM HEAD AXIAL ADJUSTMENT

39 THROATING HEAD

| Ref. No. | Description | No. Off |
|----------|--|---------|
| 1 | Nut M10 | 3 |
| 2 | Self locking nut M10 | 3 |
| 3 | Nut M10 | 2 |
| 4 | Vertical traverse screw | 1 |
| 5 | Nut M10 | 2 |
| 6 | Horizontal traverse screw | 1 |
| 7 | Throating head spindle assembly | 1 |
| 8 | Washer M10 | 9 |
| 9 | Large washer M10 | 1 |
| 10 | Collar 20mm I/D x 32mm O/D x 14mm wide | 2 |
| 11 | Flanged bush 20mm I/D x 26mm O/D x 10mm long | 4 |
| 12 | Collar 20mm I/D x 32mm O/D x 12mm wide | 2 |
| 13 | Taper pin No. 2 | 4 |
| 14 | 'SIKO' digital readout ref. 0902 E 2mm | 1 |
| 15 | 'SIKO' digital readout ref. 0904 I 2mm | 1 |
| 16 | Extraction hood and clamp for 200mm dia. saw (not shown) | 1 |

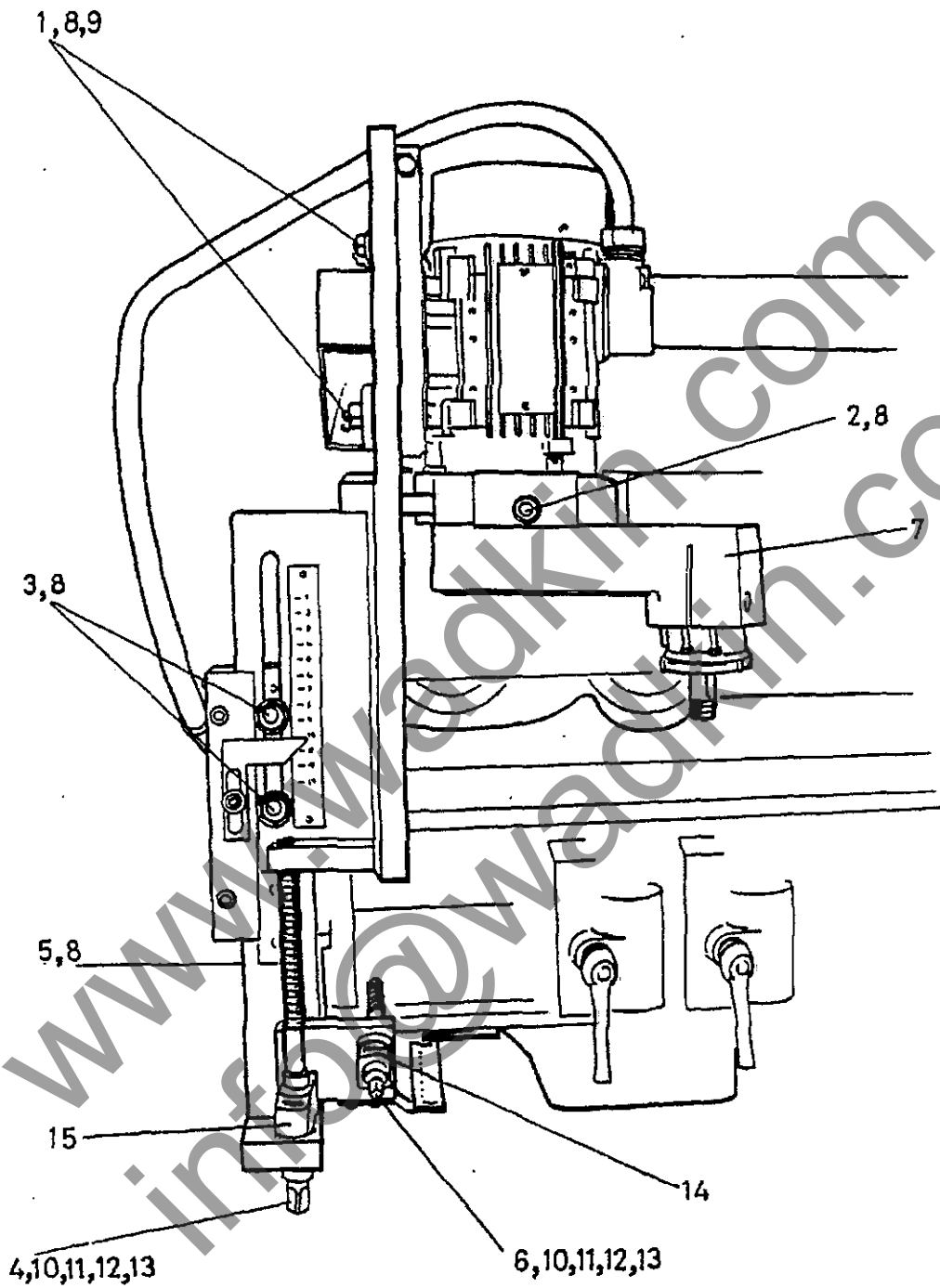

FIG 39 THROATING HEAD

40 THROATING HEAD SPINDLE ASSEMBLY

| Ref. No. | Description | No. Off |
|----------|---|---------|
| 1 | Motor | 1 |
| 2 | Friction plate | 1 |
| 3 | Hexagon socket capscrew M8 x 20mm long | 4 |
| 4 | Spigot | 1 |
| 5 | Clamp | 3 |
| 6 | Stud M10 x 40mm long | 3 |
| 7 | Self locking nut M10 | 3 |
| 8 | Washer M10 | 3 |
| 9 | Housing | 1 |
| 10 | Hexagon head setscrew M6 x 20mm long | 4 |
| 11 | Spacer for pulley | 1 |
| 12 | Motor pulley | 1 |
| 13 | Key 8mm x 30mm x 30mm long | 1 |
| 14 | Special washer | 1 |
| 15 | Hexagon socket countersunk screw M8 x 20mm long | 2 |
| 16 | Belt 'Poly vee' Ref. 180J 6 | 1 |
| 17 | Spindle pulley | 1 |
| 18 | Key 5mm x 5mm x 15mm long | 1 |
| 19 | Special washer | 1 |
| 20 | Spindle | 1 |
| 21 | Nut 3/4" x 14 T.P.I. right hand | 1 |
| 22 | Key 6mm x 6mm x 18mm long | 1 |
| 23 | Bearing housing | 1 |
| 24 | Circlip 40mm internal | 1 |
| 25 | Bearing 'SKF' 6203 - 2RS | 2 |
| 26 | Bearing spacer | 1 |
| 27 | Waved washer 'EMO' EP 34 | 1 |
| 28 | Hexagon socket capscrew M8 x 60mm long | 1 |
| 29 | Hexagon head setscrew M5 x 25mm long | 2 |
| 30 | Nut M5 | 2 |
| 31 | Cover | 1 |
| 32 | Hexagon head setscrew M5 x 10mm long | 3 |



ILLUSTRATED PARTS LIST

SECTION

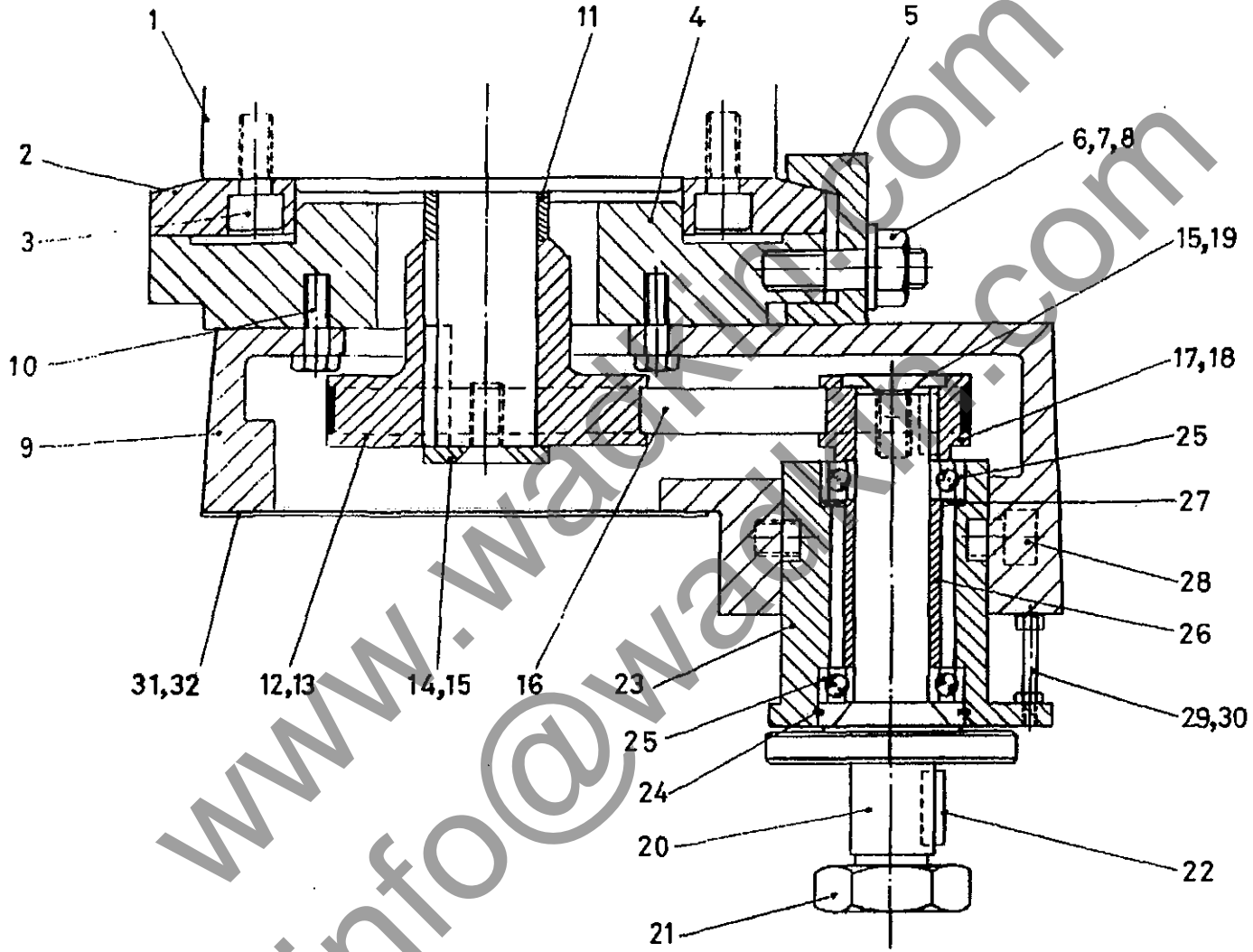

FIG 40 THROATING HEAD SPINDLE ASSEMBLY



41 HYDRAULIC DRIVE UNIT

| Ref. No. | Description | No. Off |
|----------|---|---------|
| 1 | Inlet/return hose; SAE 100R2AT, 3/4" bore x 3 metres long, 45 degree flange 3/4" and 90 degree flange 1" end fittings | 2 |
| 2 | Vent hose; SAE 100RIT, 5/8" bore x 3 metres long, stand pipe fittings both ends (including olive and nut) | 1 |
| 3 | Flange kit 16PA to suit 1" end fitting (includes 2 flange halves, 4 bolts, 4 washers and 'O' rings) | 2 |
| 4 | Hydraulic motor 'Linde' BMF 35TFC | 1 |
| 5 | Variable displacement axial piston pump 'Linde' BPV 1005 | 1 |
| 6 | Cooler/reservoir assembly driven by 40 hp, 200 LD frame, 3 phase electric motor | 1 |
| 7 | Top vent hose from pump to oil reservoir | 1 |
| 8 | External suction hose from reservoir to pump | 1 |
| 9 | Filter hose | 1 |
| 10 | Flange kit 12 PA to suit 3/4" end fitting (includes 2 flange halves, 4 bolts, 4 washers and 'O' rings) | 2 |

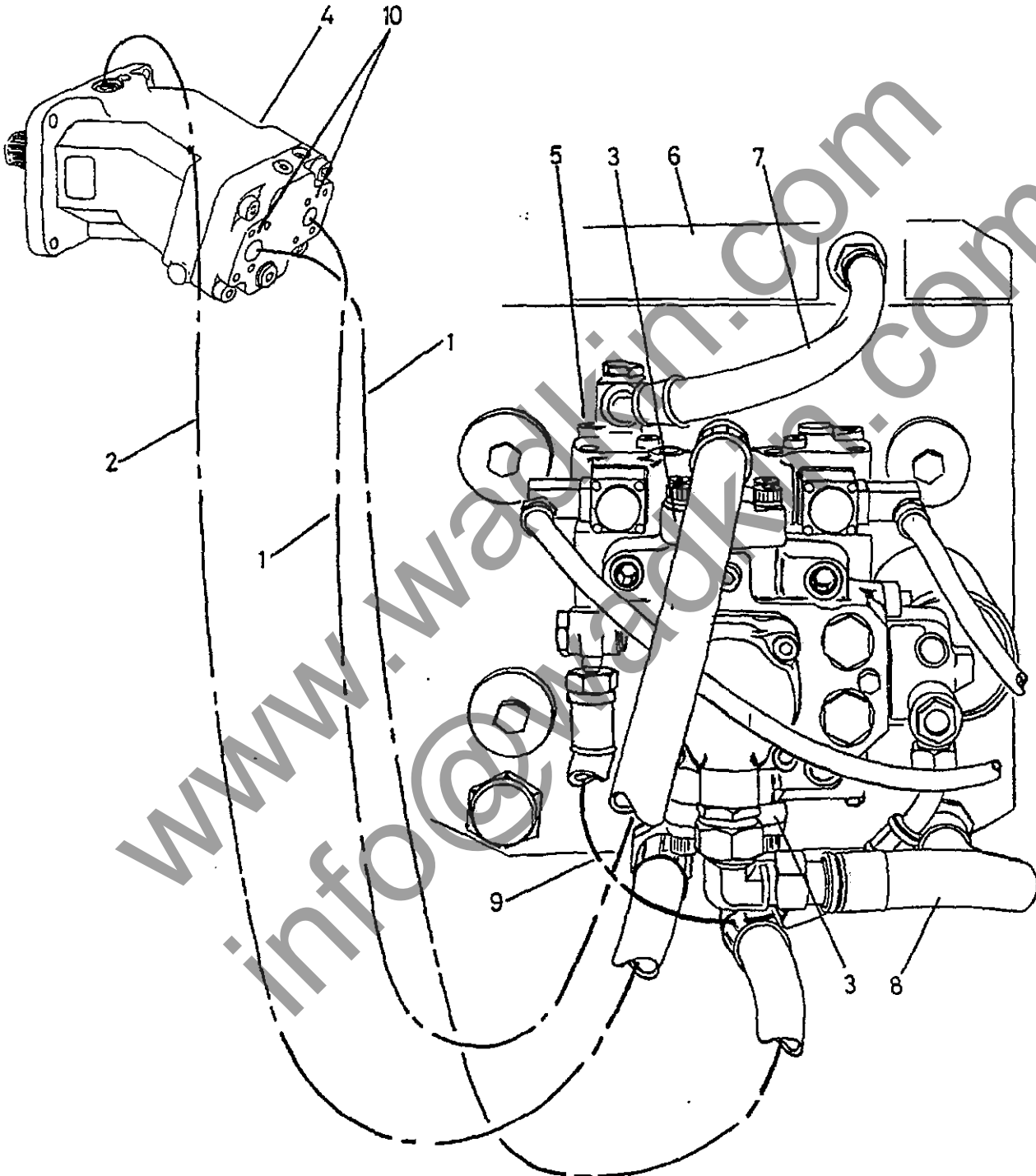

FIG 41 HYDRAULIC DRIVE UNIT.

**42 BOTTOM HEAD PAD PRESSURE**

| Ref no. | Description | No. off |
|---------|--------------------|---------|
| 1 | Mounting Bracket | 1 |
| 2 | Saddle | 1 |
| 3 | Pressure Mounting | 1 |
| 4 | Slide for Pressure | 1 |
| 5 | Pressure Pad | 1 |
| 6 | Handwheel | 1 |

www.wadkin.com
info@wadkin.com

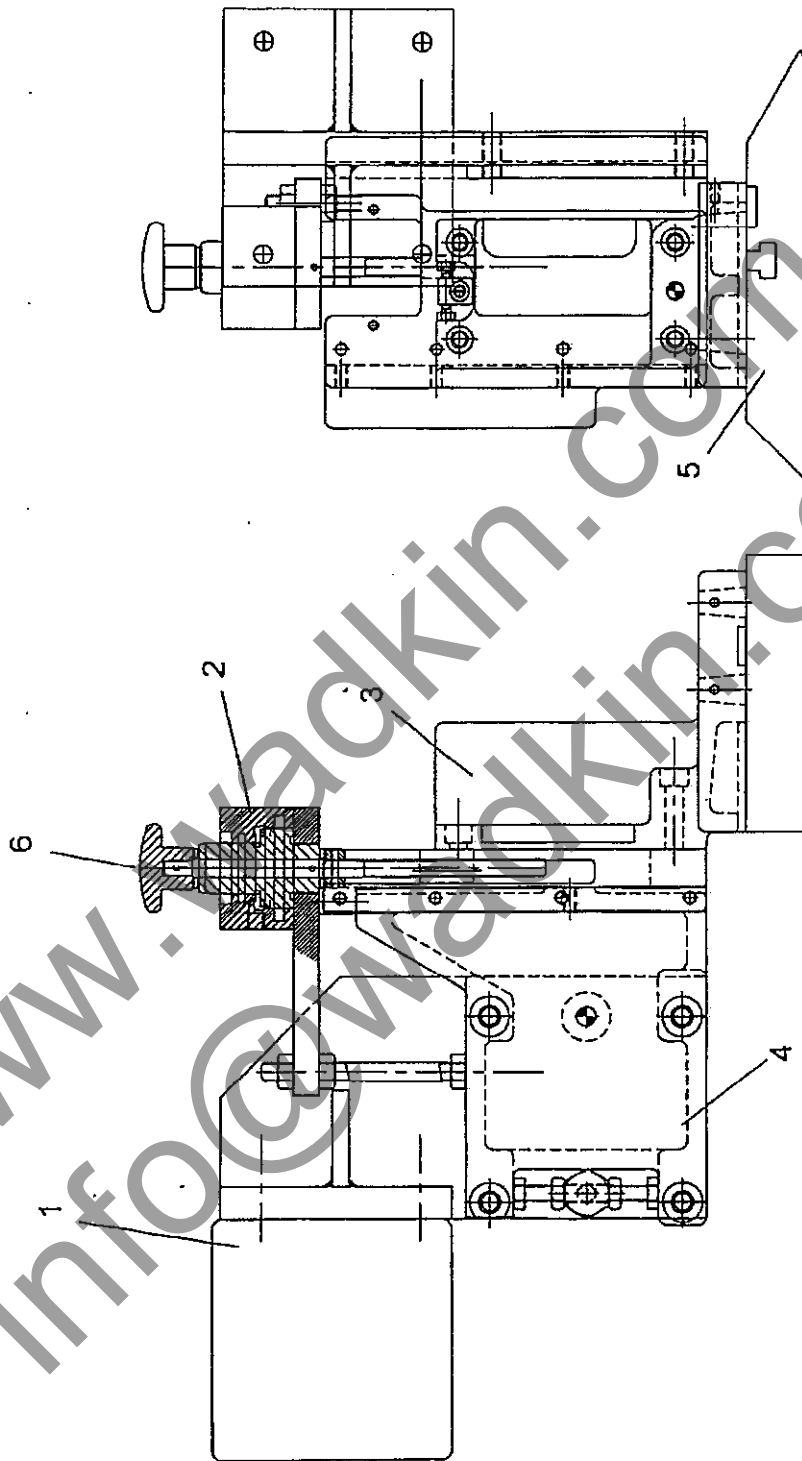

FIG 42 BOTTOM HEAD PAD PRESSURE

**43 PNEUMATIC PAD PRESSURE**

| Ref no. | Description | No. off |
|---------|-----------------------------|---------|
| 1 | Pneumatic Cylinder (Norgen) | 1 |
| 2 | Handwheel | 1 |
| 3 | Cylinder Plate | 1 |
| 4 | Pressure Slide | 1 |
| 5 | Pad Pressure Segment | 18 |
| 6 | Compression Spring | 36 |
| 7 | Segment Block | 1 |
| 8 | Adjusting Screw | 1 |

www.wadkin.com
info@wadkin.com

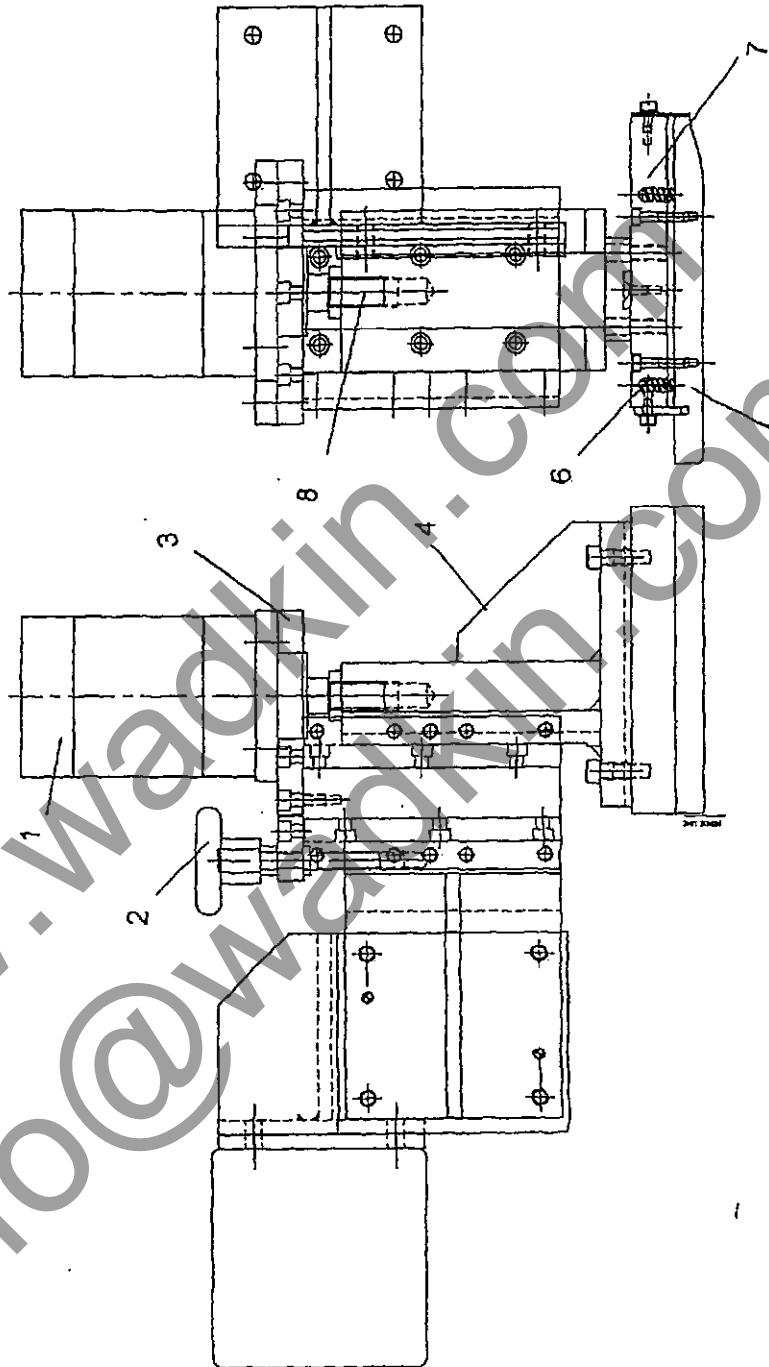

FIG 43 PNEUMATIC PAD PRESSURE

43 PNEUMATIC PAD PRESSURE

| Ref no. | Description | No. off |
|----------------|-----------------------------|----------------|
| 1 | Pneumatic Cylinder (Norgen) | 1 |
| 2 | Handwheel | 1 |
| 3 | Cylinder Plate | 1 |
| 4 | Pressure Slide | 1 |
| 5 | Pad Pressure Segment | 18 |
| 6 | Compression Spring | 36 |
| 7 | Segment Block | 1 |
| 8 | Adjusting Screw | 1 |

www.wadkin.com
info@wadkin.com

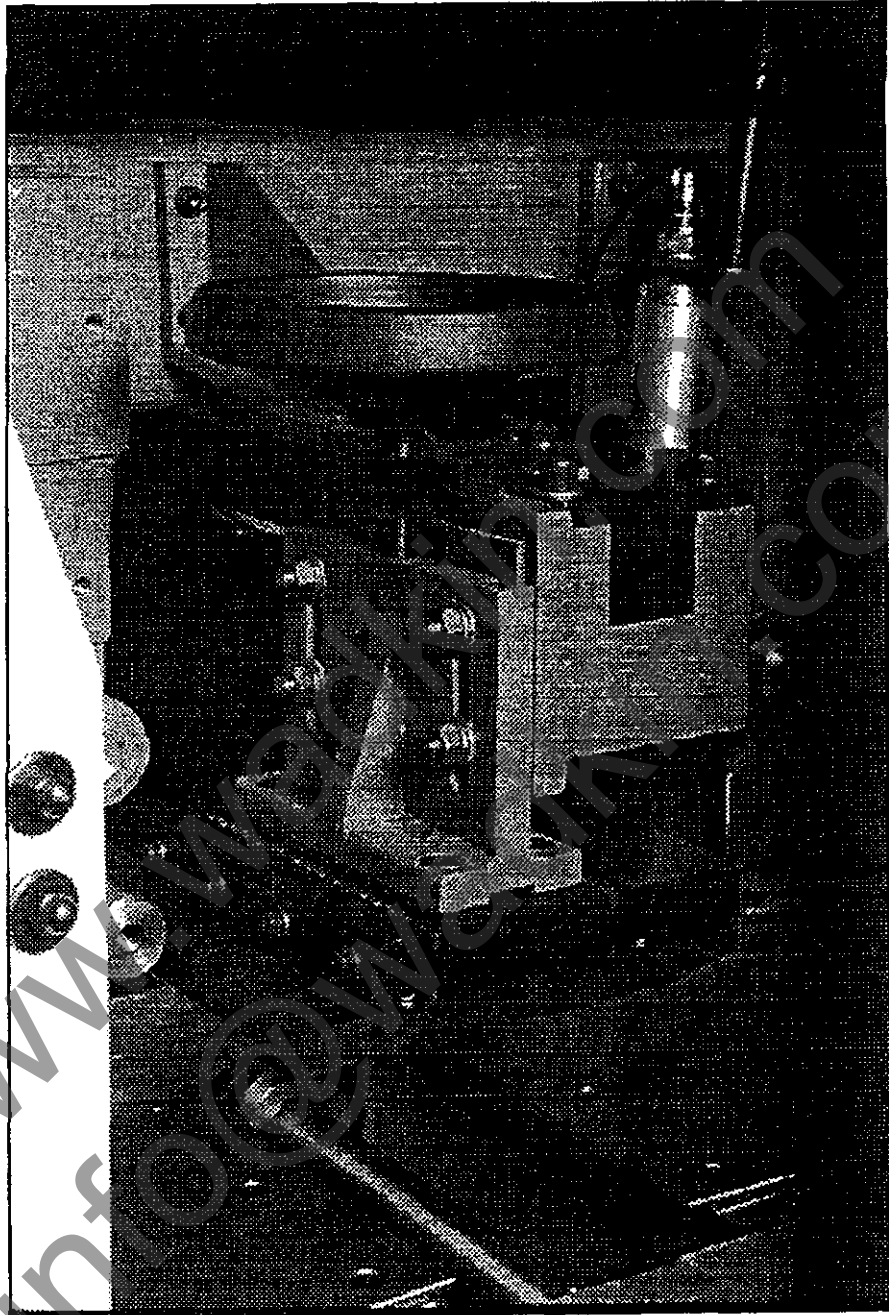

FIG 43 PNEUMATIC PAD PRESSURE

44 SEGMENTED CHIPBREAKER

| Ref no. | Description | No. off |
|----------------|--------------------|----------------|
| 1 | Chipbreaker Finger | 19 |
| 2 | Spring | 19 |
| 3 | Mounting Bracket | 1 |
| 4 | Adjusting Screw | 1 |
| 5 | Locking nuts | 4 |

www.wadkin.com
info@wadkin.com

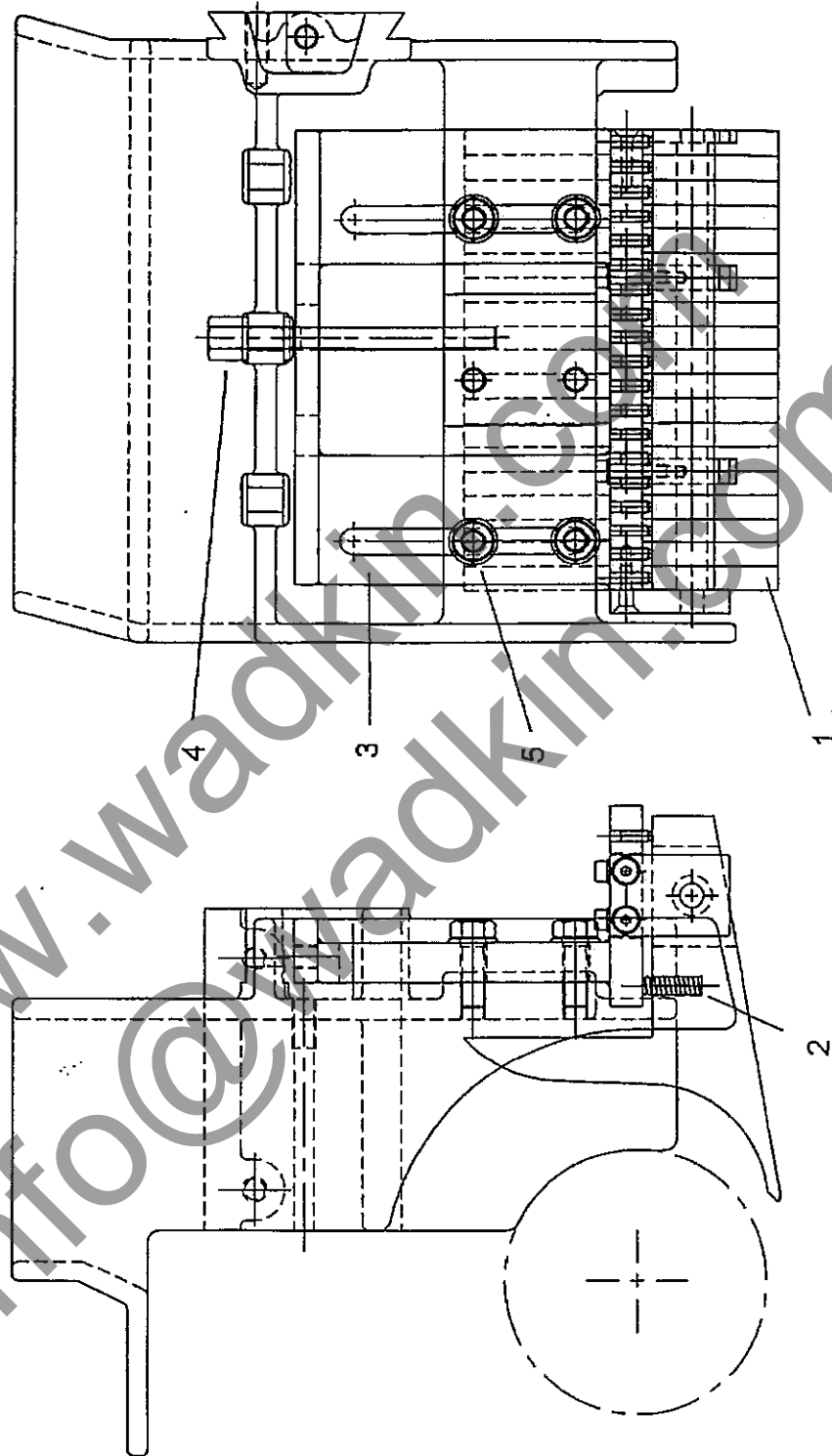

FIG 44 SEGMENTED CHIPBREAKER

44 SEGMENTED CHIPBREAKER

| Ref no. | Description | No. off |
|----------------|--------------------|----------------|
| 1 | Chipbreaker Finger | 19 |
| 2 | Spring | 19 |
| 3 | Mounting Bracket | 1 |
| 4 | Adjusting Screw | 1 |
| 5 | Locking nuts | 4 |

www.wadkin.com
info@wadkin.com

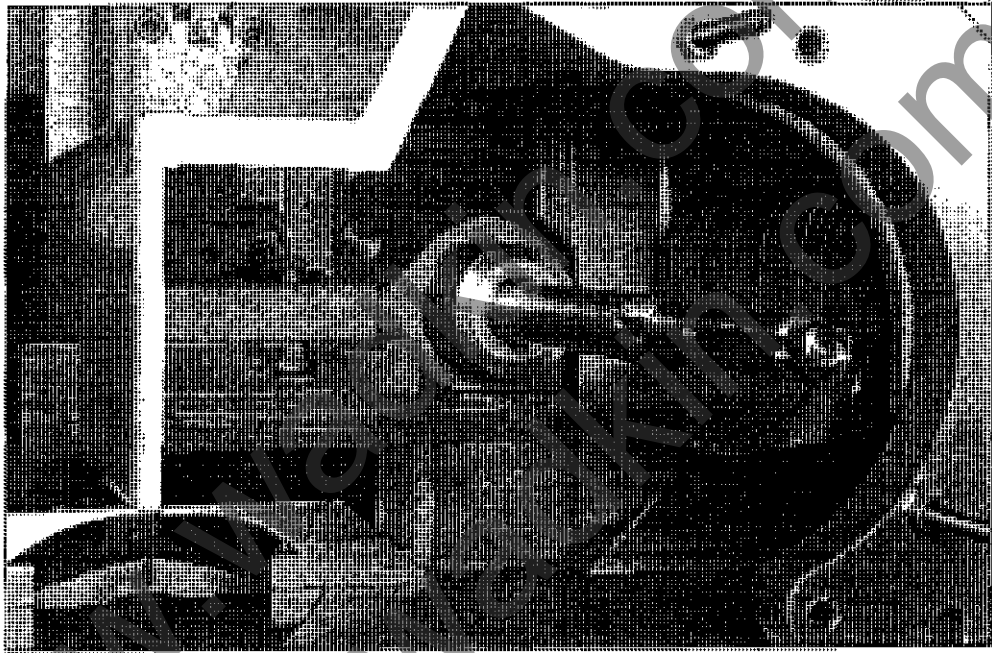

FIG 44 SEGMENTED CHIPBREAKER



45 PUSH FEED SYSTEM

| Ref no. | Description | No. off |
|----------------|----------------------------------|----------------|
| 1 | Top Roller | 2 |
| 2 | Bottom Roller | 2 |
| 3 | Side Skid Pressure Roller | 1 |
| 4 | Side Pressure Roller | 1 |
| 5 | Top Cylinder | 2 |
| 6 | Air Switch | 1 |
| 7 | Set Screw (Bottom) (Factory Set) | 2 |
| 8 | Set Screw (Top) (Factory Set) | 2 |
| 9 | Air Cylinder | 2 |

www.wadkin.com
info@wadkin.com

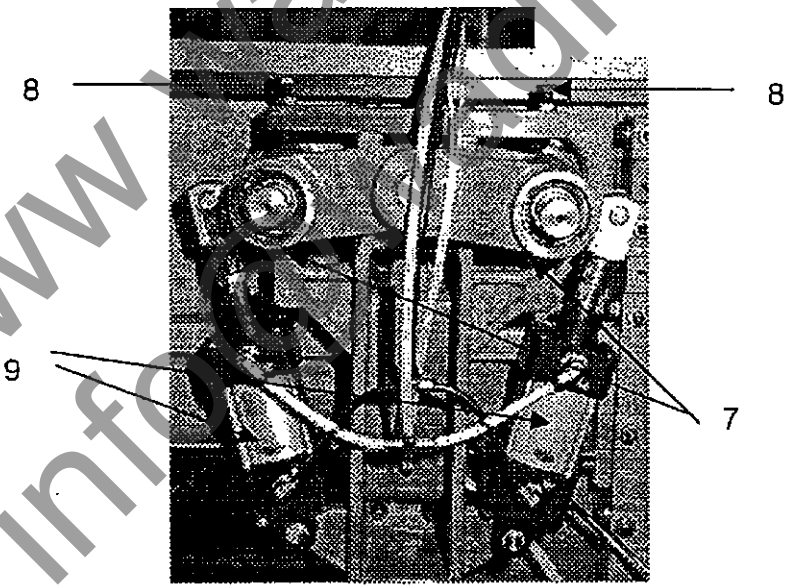
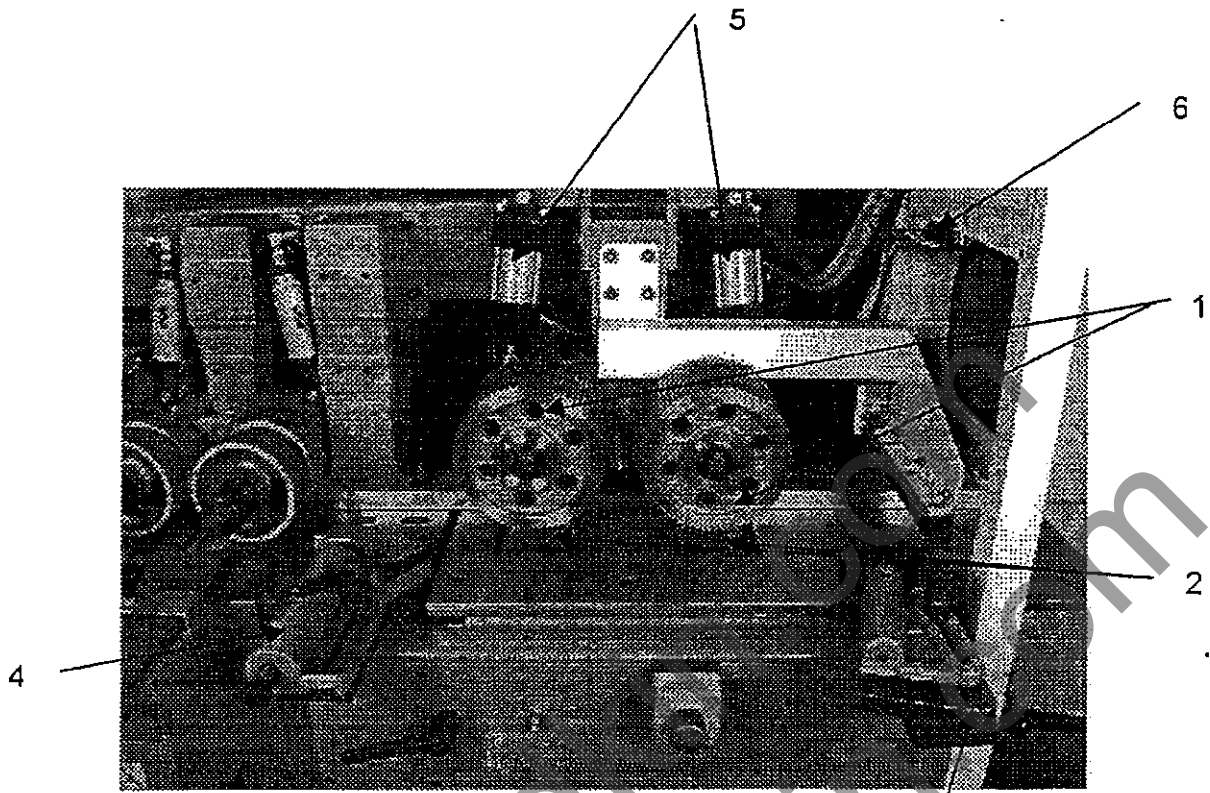

REAR VIEW

FIG 45 PUSH FEED SYSTEM

Close Coupled Side Heads

ILLUSTRATED PARTS LIST

CONTENTS

1. Near Side Head Rise and Fall
2. Near Side Head Lateral Adjustment
3. Near Side Head Spindle and Carriage Locks
4. Fence Side Head Lateral Adjustment
5. Fence Side Head Rise and Fall

IMPORTANT: When ordering spares always quote model and machine number.

www.wadkin.com
info@wadkin.com

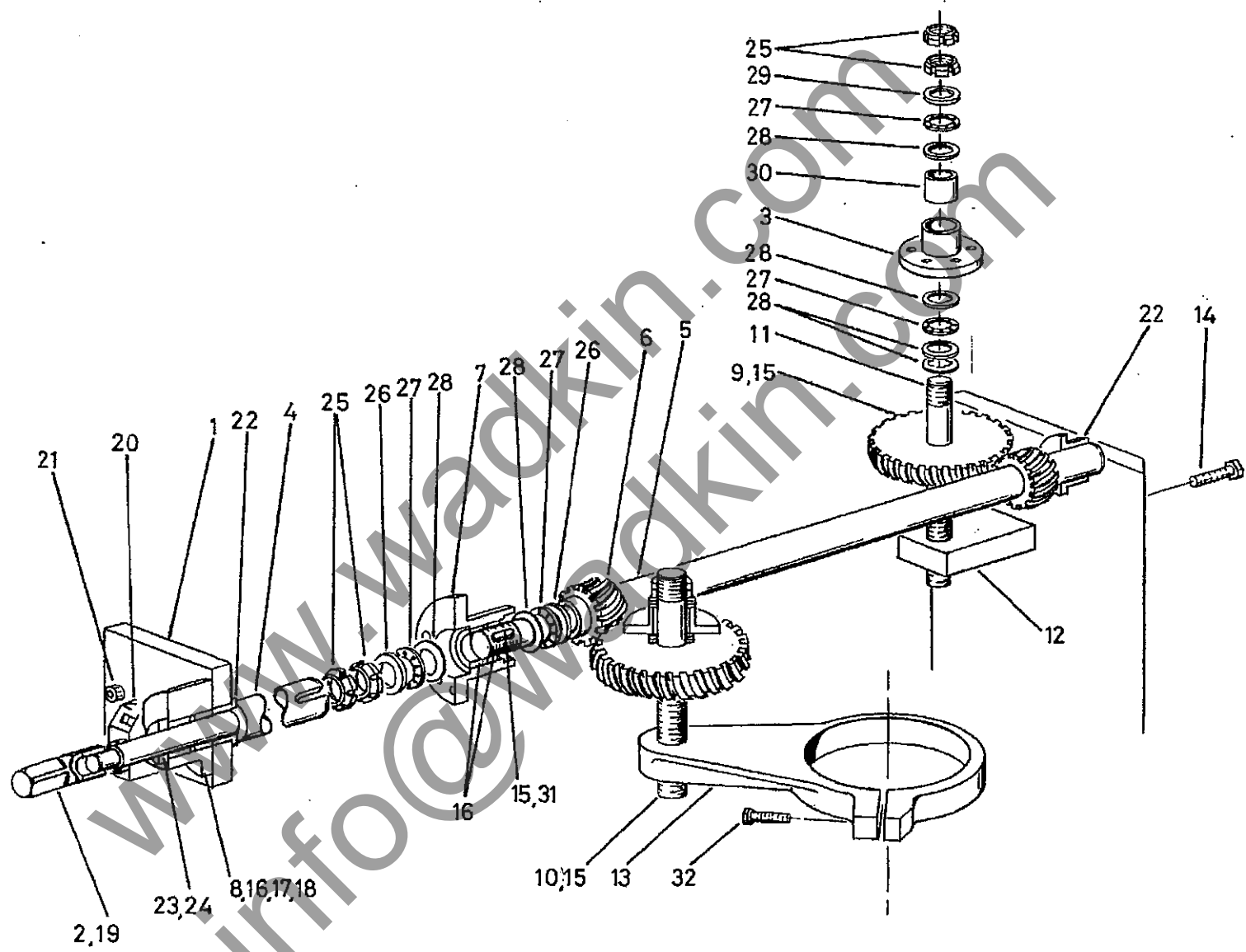

Close Coupled Side Heads

Close Coupled Side Heads

1. NEAR SIDE HEAD RISE AND FALL

| Ref No. | Description | No. Off |
|---------|--|---------|
| 1. | Plate for shaft extension | 1 |
| 2. | Square end shaft extension | 1 |
| 3. | Housing for vertical shaft bearings | 2 |
| 4. | Extension shaft | 1 |
| 5. | Horizontal winding shaft | 1 |
| 6. | Pinion | 2 |
| 7. | Housing for horizontal shaft bearings | 1 |
| 8. | Bracket for shaft bearing | 1 |
| 9. | Gear | 2 |
| 10. | Rise and fall leadscrew (left hand thread) | 1 |
| 11. | Rise and fall leadscrew (right hand thread) | 1 |
| 12. | Screw block for motor slide | 1 |
| 13. | Adjusting screw clamp for spindle barrel | 1 |
| 14. | Hexagon head setscrew M12 x 45mm long | 2 |
| 15. | Key 6mm x 6mm x 20mm long | 3 |
| 16. | Bronze bush 25mm O/D x 20mm I/D x 15mm long | 4 |
| 17. | Hexagon socket capscrew M8 x 16mm long | 2 |
| 18. | Plain washer M8 | 2 |
| 19. | Taper pin No.1 | 1 |
| 20. | 'SIKO' digital indicator 0902E 4mm | 1 |
| 21. | Hexagon socket capscrew M8 x 25mm long | 2 |
| 22. | Bronze headed bush 26mm O/D x 20mm I/D x 15mm long | 2 |
| 23. | Locking collar | 1 |
| 24. | Hexagon socket grubscrew M6 x 6mm long | 1 |
| 25. | Notch nut M20 x 1.5mm | 6 |
| 26. | Shaft washer 'INA' WS81104 | 4 |
| 27. | Thrust bearing 'INA' AXK 2035 | 6 |
| 28. | Thrust washer 'INA' AS 2035 | 8 |
| 29. | Thrust washer 'INA' WS 81104 | 2 |
| 30. | Bronze bush 25mm O/D x 20mm I/D x 20mm long | 2 |
| 31. | Hexagon socket capscrew M4 x 12mm long | 1 |
| 32. | Hexagon head setscrew M10 x 55mm long | 1 |

NOTE: Both leadscrew assemblies are identical apart from the 'Handed'

Close Coupled Side Heads

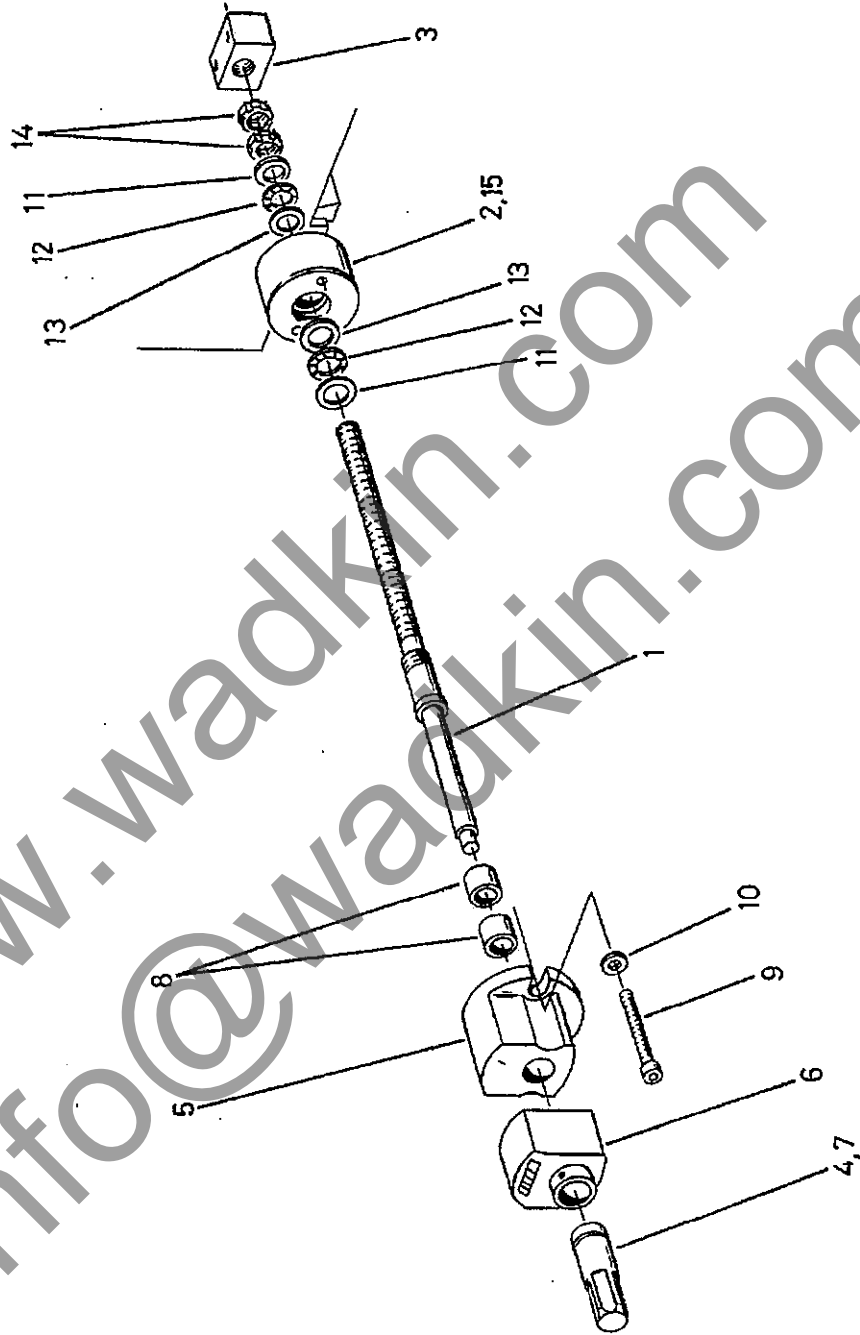

Close Coupled Side Heads

2. NEAR SIDE HEAD LATERAL ADJUSTMENT

| Ref No. | Description | No Off. |
|---------|---|---------|
| 1. | Screw for cross traverse | 1 |
| 2. | Housing for traverse screw bearings | 1 |
| 3. | Nut traverse | 1 |
| 4. | Shaft extension | 1 |
| 5. | Bracket for shaft bearings | 1 |
| 6. | 'SIKO' digital indicator 0902 I 2mm | 1 |
| 7. | Taper pin No.1 | 1 |
| 8. | Bronze bush 25mm O/D x 20mm I/D x 15mm long | 2 |
| 9. | Hexagon socket capscrew M8 x 60mm long | 2 |
| 10. | Plain washer M8 | 2 |
| 11. | Thrust washer 'INA' LS 2542 | 2 |
| 12. | Thrust bearing 'INA' AXK 2542 | 2 |
| 13. | Thrust washer 'INA' AS 2542 | 2 |
| 14. | Notch nut M24 x 1.5mm P. | 2 |
| 15. | Bronze bush 30mm O/D x 25mm I/D x 20mm long | 1 |

Close Coupled Side Heads

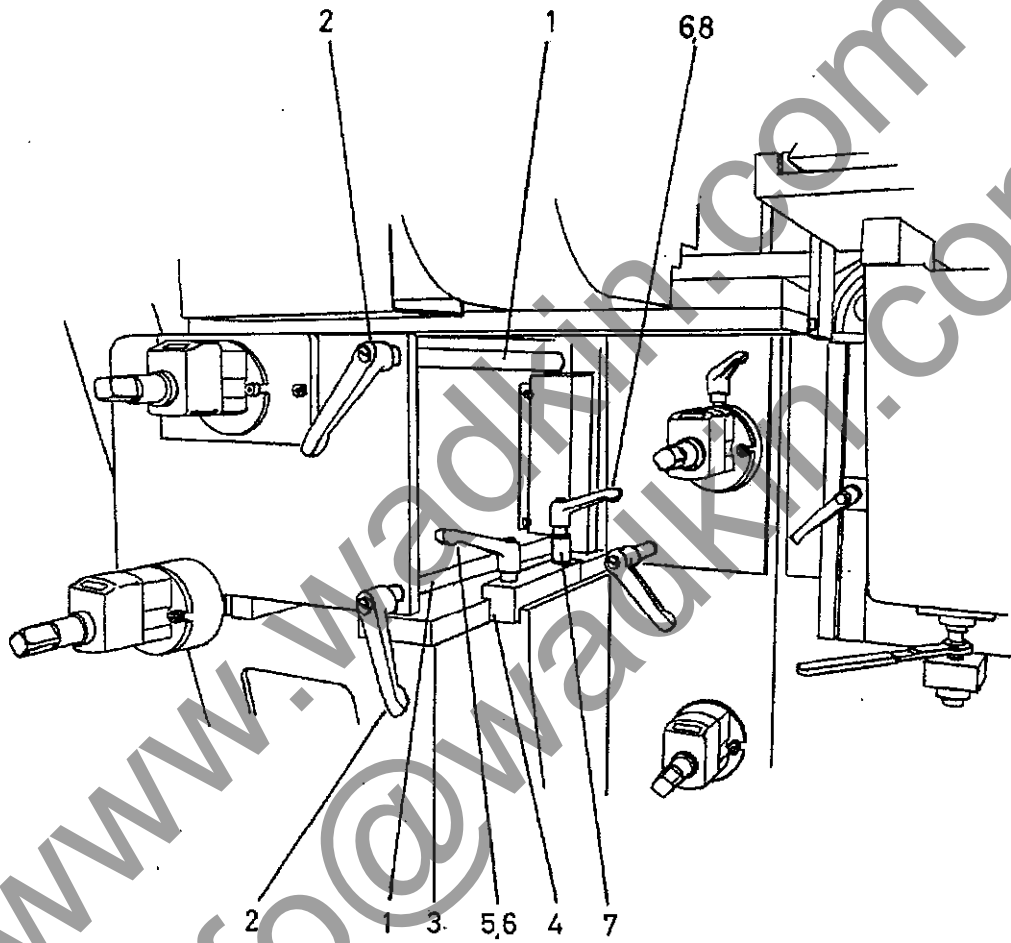

Close Coupled Side Heads

3. NEAR SIDE HEAD SPINDLE AND CARRIAGE LOCKS

| Ref No. | Description | No Off. |
|---------|--|---------|
| 1. | Shaft for side head lock | 2 |
| 2. | Handle (male) M12 x 25mm | 2 |
| 3. | Slide plate | 1 |
| 4. | Lock bar | 1 |
| 5. | Stud M12 x 70mm long | 2 |
| 6. | Kipp handle (female) M12 | 2 |
| 7. | Spacing collar 25mm O/D x 14mm I/D x 50mm long | 1 |
| 8. | Stud M12 x 125mm long | 1 |

www.wadkin.com
info@wadkin.com

Close Coupled Side Heads

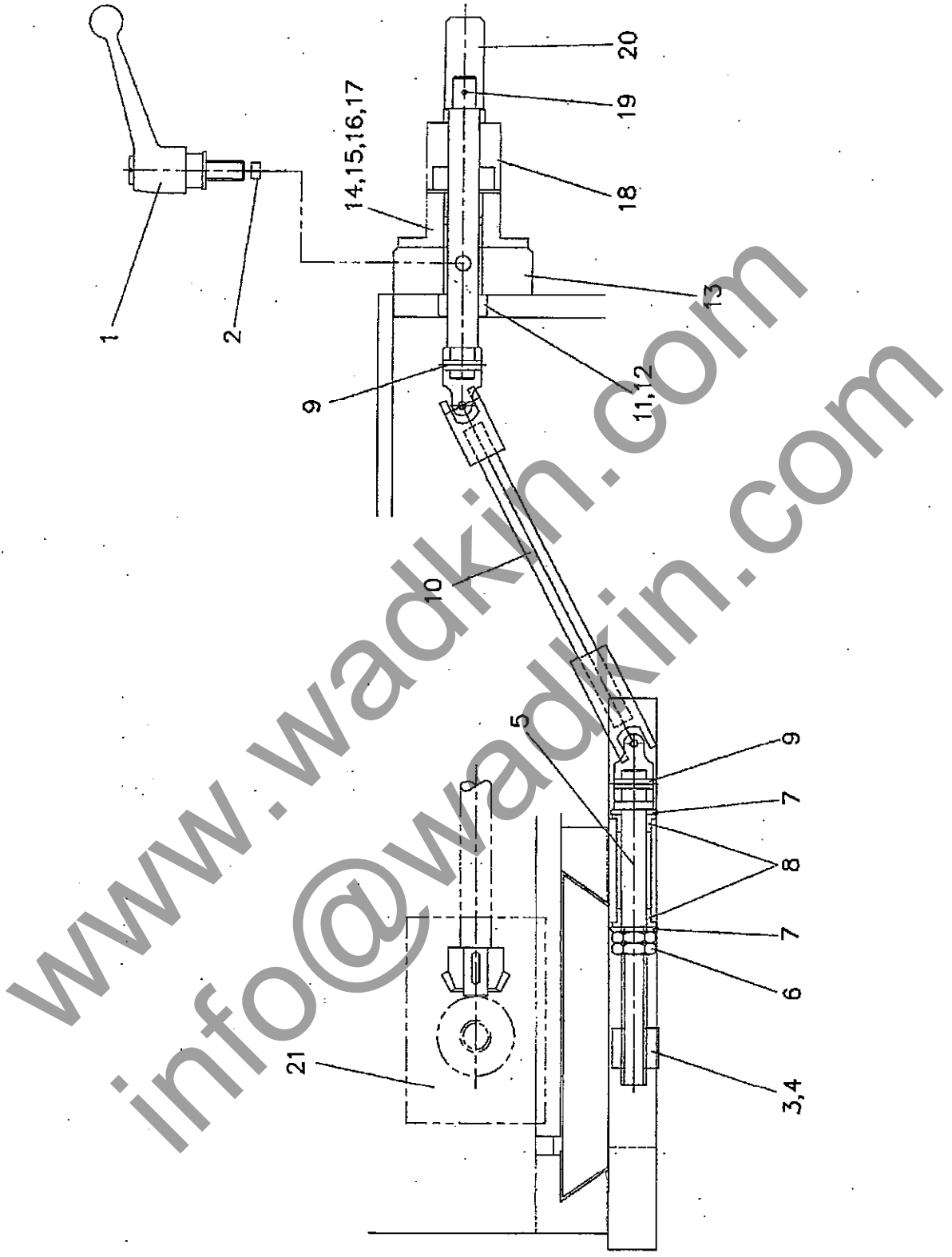

Close Coupled Side Heads

4. FENCE SIDE HEAD LATERAL ADJUSTMENT

| Ref No. | Description | No Off. |
|---------|--|---------|
| 1. | Locking handle | 1 |
| 2. | Brass pad | 1 |
| 3. | Traverse nut | 1 |
| 4. | Hexagon socket capscrew M8 x 35mm long | 2 |
| 5. | Traverse screw | 1 |
| 6. | Nut M16 | 2 |
| 7. | Washer M16 | 2 |
| 8. | Flanged bush 16mm I/D x 22mm O/D x 12mm long | 2 |
| 9. | Tension pin dia. 6mm x 24mm long | 2 |
| 10. | Universal coupling shaft | 1 |
| 11. | Collar | 1 |
| 12. | Hexagon socket grubscrew M6 x 6mm long | 1 |
| 13. | Spacer | 1 |
| 14. | Housing | 1 |
| 15. | Bush 20mm I/D x 25mm O/D x 15mm long | 2 |
| 16. | Hexagon socket capscrew M8 x 50mm long | 2 |
| 17. | Washer M8 | 2 |
| 18. | 'SIKO' indicator - 0902E 2mm | 1 |
| 19. | Taper pin No.1 | 1 |
| 20. | Square end | 1 |
| 21. | Rise and fall gearbox (Shown for reference) | 1 |

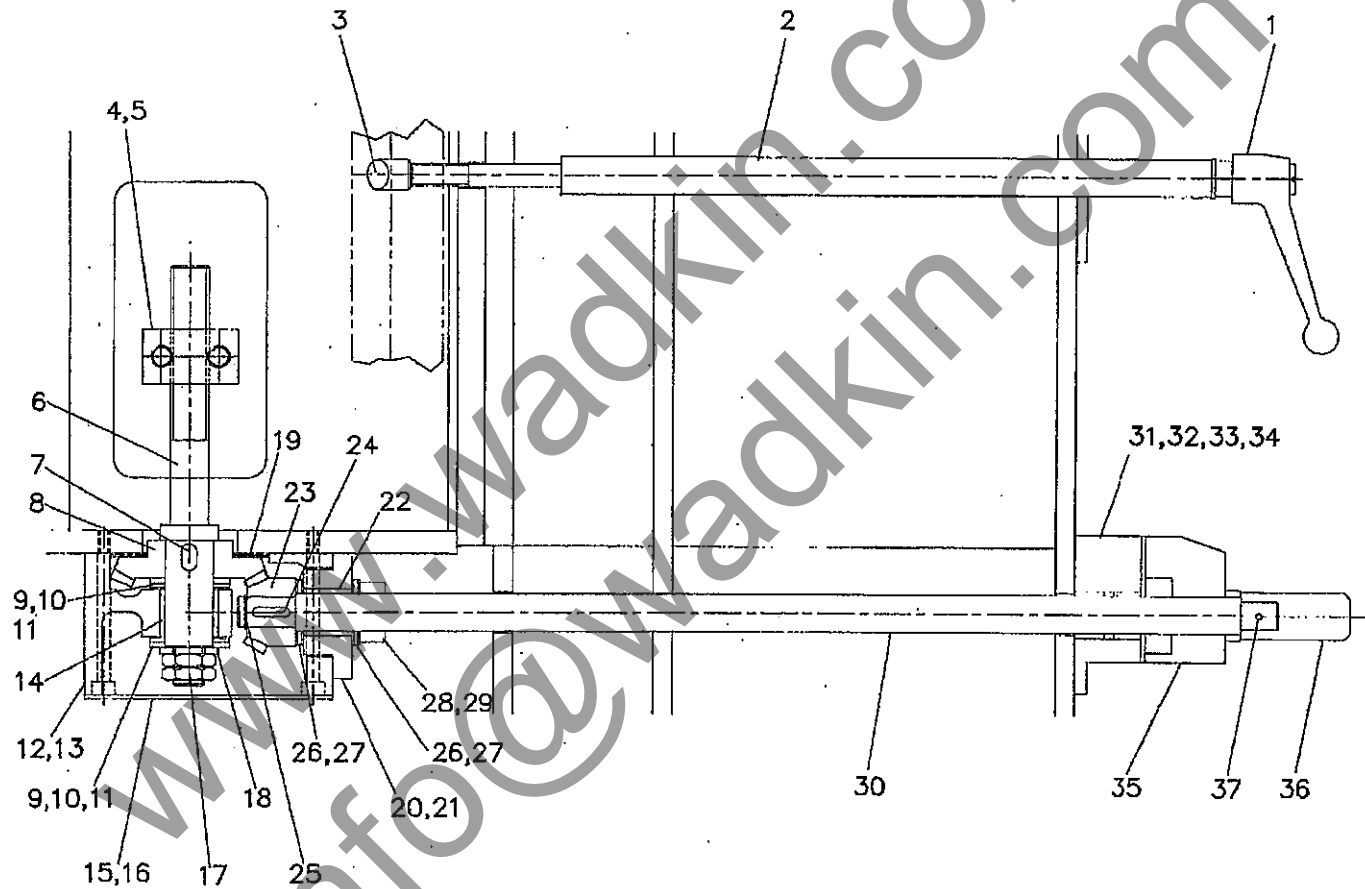

Close Coupled Side Heads

Close Coupled Side Heads

5. FENCE SIDE HEAD RISE AND FALL

| Ref No. | Description | No Off. |
|---------|---|---------|
| 1. | Locking handle | 1 |
| 2. | Locking shaft | 1 |
| 3. | Clamping pad | 1 |
| 4. | Rise and fall nut | 1 |
| 5. | Hexagon socket capscrew M12 x 35mm long | 2 |
| 6. | Rise and fall screw | 1 |
| 7. | Key 8mm x 7mm x 14mm long | 1 |
| 8. | Bevel gear 32 teeth | 1 |
| 9. | 'INA' Thrust bearing AXK 2542 | 2 |
| 10. | 'INA' Thrust washer AS 2542 | 2 |
| 11. | 'INA' Thrust washer WS 81105 | 2 |
| 12. | Bevel gear box | 1 |
| 13. | Hexagon socket capscrew M6 x 75mm long | 4 |
| 14. | Bush 25mm I/D x 30mm O/D x 25mm long | 1 |
| 15. | Cover | 1 |
| 16. | Pan head screw M4 x 10mm long | 3 |
| 17. | Locknut M16 | 2 |
| 18. | Washer M16 | 1 |
| 19. | Sealing ring | 1 |
| 20. | End cap | 1 |
| 21. | Hexagon socket capscrew M6 x 20mm long | 3 |
| 22. | Bush 20mm I/D x 25mm O/D x 25mm long | 1 |
| 23. | Bevel gear 16 teeth | 1 |
| 24. | Key 5mm x 5mm x 20mm long | 1 |
| 25. | Circlip - 16mm dia. external | 1 |
| 26. | 'INA' Thrust bearing AXK 2035 | 2 |
| 27. | 'INA' Thrust washer AS 2035 | 4 |
| 28. | Collar | 1 |
| 29. | Hexagon socket grubscrew M6 x 6mm long | 1 |
| 30. | Shaft | 1 |
| 31. | Housing | 1 |
| 32. | Bush 20mm I/D x 25mm O/D x 15mm long | 2 |
| 33. | Hexagon socket capscrew M8 x 20mm long | 2 |
| 34. | Washer M8 | 2 |
| 35. | 'SIKO' indicator 0902 I 2mm | 1 |
| 36. | Square end | 1 |
| 37. | Taper pin No.1 | 1 |